

Structural Engineering, Mechanics and Materials  
Research Report No. 07-1

---

**Guideline for the Design of Stainless Steel Structures**  
**Part 1: Dimensions and Section Properties**

---

Prepared For:



**Stainless Structural**  
L.L.C.

By:

**Abdul-Hamid Zureick, Ph.D.**  
**Leroy Z. Emkin, Ph.D., P.E., F.ASCE**  
**Gwangseok Na, Ph.D. Student**

February 2007

---

# Guideline for the Design of Stainless Steel Structures

## Part 1 - Dimensions and Section Properties

---

### Revision History

<u>Revision No.</u>	<u>Date Released</u>	<u>Description</u>
N/A	2/2007	First Edition. It is not intended that the dimensions and section properties in this First Edition be used for analysis or design purposes. Rather, it is intended that the format of this document, and the type and numerical values of information displayed herein be reviewed by the engineering community. Constructive criticism is sought from said community for consideration by the authors and Stainless Structural LLC for the preparation of future editions.

**Note that the data is functional only with shapes made by and/or certified by Stainless Structural, LLC. They are not to be used with uncertified shapes, as dimensions, mechanical properties and methods of manufacture vary.**

Please access our web site at [www.stainless-structurals.com](http://www.stainless-structurals.com) for the most up-to-date information and range of available sections. New shapes and ancillary information are being added on a regular basis.

---

# Disclaimer

---

STAINLESS STRUCTURALS LLC, GEORGIA TECH RESEARCH CORP. AND GEORGIA INSTITUTE OF TECHNOLOGY DISCLAIM ANY AND ALL WARRANTIES BOTH EXPRESS AND IMPLIED WITH RESPECT TO THE SERVICES TO BE PERFORMED HEREUNDER AND ANY DELIVERABLES RESULTING THEREFROM, INCLUDING THEIR CONDITION, CONFORMITY TO ANY REPRESENTATION OR DESCRIPTION, THE EXISTENCE OF ANY LATENT OR PATENT DEFECTS THEREIN, AND THEIR MERCHANTABILITY OR FITNESS FOR A PARTICULAR USE OR PURPOSE.

Copyright © 2007  
by  
Stainless Structurals, LLC.  
Jacksonville, Florida 32254 USA

All rights reserved  
Printed in the United States of America

---

# P r e f a c e

---

The Georgia Institute of Technology and Stainless Structural, LLC intend to develop a guideline for the design of stainless steel structures. The first phase of this effort is the development of a set of section properties for stainless steel rolled and laser-fused shapes used for construction. This document contains section property tables for five shapes currently produced by Stainless Structural, LLC. It is anticipated that the number of such tables will be increased and documented through updates to this document as new information becomes available.

Further, as subsequent phases of this effort are completed, this document also will be updated.

---

# Table of Contents

---

<b>Section</b>	<b>Page</b>
Revision History	i
Disclaimer	ii
Preface	iii
Table of Contents	iv
Part 1 - Dimensions and Properties	1
W Shapes - Dimensions and properties	2
W Shapes (Laser Fused)	3
S Shapes - Dimensions and properties	9
S Shapes (Laser Fused)	10
S Shapes (Hot Rolled)	11
C Shapes - Dimensions and properties	12
C Shapes (Laser Fused)	13
C Shapes (Hot Rolled)	14
T Shapes - Dimensions and properties	15
T Shapes (Laser Fused)	16
T Shapes (Hot Rolled)	18
L Shapes Equal Legs - Dimensions and properties ( y & z axes )	19
L Shapes Equal Legs ( y & z axes )	20
L Shapes Equal Legs - Dimensions and properties ( u & v axes )	22
L Shapes Equal Legs ( u & v axes )	23
L Shapes Unequal Legs - Dimensions and properties ( y & z axes )	25
L Shapes Unequal Legs (Laser Fused) ( y & z axes )	26
L Shapes Unequal Legs (Hot Rolled) ( y & z axes )	27
L Shapes Unequal Legs - Dimensions and properties ( u & v axes )	28
L Shapes Unequal Legs (Laser Fused) ( u & v axes )	29
L Shapes Unequal Legs (Hot Rolled) ( u & v axes )	30

## STAINLESS STRUCTURALS PRODUCTS

The dimensions and properties for Stainless Structurals Products used in construction are given in this part of the guideline. For design purposes, each cross section is referenced with respect to a local Cartesian coordinate system  $(x,y,z)$  where the local  $x$ -axis coincides with the centroidal longitudinal axis of the member, while the local  $y$ - and  $z$ -axes coincide with the principal axes of the member cross-section as shown in Figure 1.

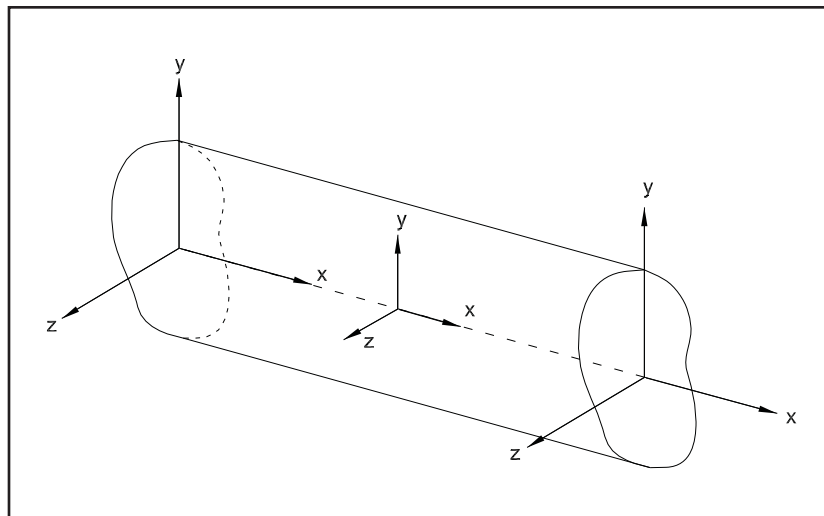
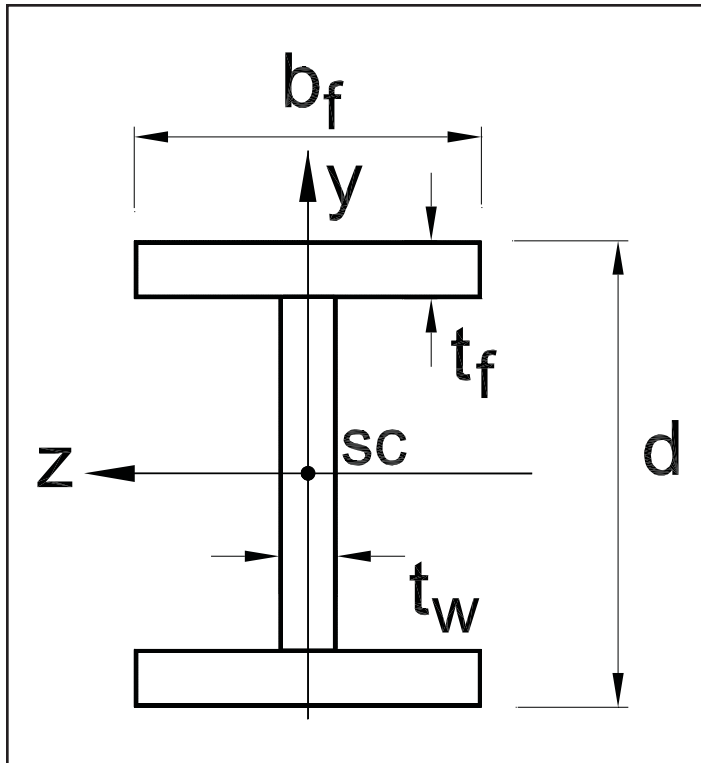

Figure 1. Local Member Reference Frame

Five types of cross section shapes are covered in this document. These are: W-shapes, S-shapes, Channels or C-shapes, Structural Tees, and Angles. Properties of these shapes include cross section area, shear areas, torsion constant, moments of inertia, product moments of inertia, section moduli, radii of gyration, warping constant, centroid and shear center locations, and principal axis orientation, and are computed in accordance with accepted engineering principles. All calculations are carried out by means of a computer program **CIMTEC Calc** developed by the authors. Reported section property values are rounded as follows:

- to the nearest whole number when the computed value is 100 or greater,
- to the nearest one-tenth when the computed value is between 10 and 99,
- to the nearest one-hundredth when the computed value is between 1 and 9, and
- to the nearest ten-thousandth when the computed value is a number less than 1.



### DIMENSIONS AND PROPERTIES OF LASER-FUSED W SHAPES

Dimensions and properties of laser-fused W shapes are given in this section. The following notations are used in these tables.

- $A$  Gross cross sectional area of the section
- $d$  Full nominal depth of the section
- $t_w$  Web thickness
- $b_f$  Flange width
- $t_f$  Flange thickness
- $A_z$  Shear area with respect to the principal axis  $z$
- $I_z$  Moment of inertia about the principal axis  $z$
- $S_z$  Elastic section modulus corresponding to the principal axis  $z$
- $r_z$  Radius of gyration corresponding to the principal axis  $z$
- $A_y$  Shear area with respect to the principal axis  $y$
- $I_y$  Moment of inertia about the principal axis  $y$
- $S_y$  Elastic section modulus corresponding to the principal axis  $y$
- $r_y$  Radius of gyration corresponding to the principal axis  $y$
- $J$  Torsion constant
- $C_w$  Warping constant
- $SC$  Shear center

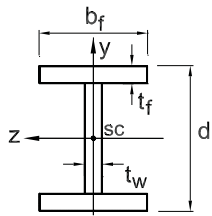

# W Shapes (Laser Fused)

## Dimensions and Properties

Shape	Web		Flange		Axis z-z				Axis y-y				Torsion Properties		
	A	d	t <sub>w</sub>	b <sub>f</sub>	t <sub>f</sub>	A <sub>z</sub>	I <sub>z</sub>	S <sub>z</sub>	r <sub>z</sub>	A <sub>y</sub>	I <sub>y</sub>	S <sub>y</sub>	r <sub>y</sub>	J	C <sub>w</sub>
	in. <sup>2</sup>	in.	in.	in.	in.	in. <sup>2</sup>	in. <sup>4</sup>	in. <sup>3</sup>	in.	in. <sup>2</sup>	in. <sup>4</sup>	in. <sup>3</sup>	in.	in. <sup>4</sup>	in. <sup>6</sup>
W 4x13	3.77	4.16	0.280	4.060	0.345	2.39	11.2	5.38	1.72	1.01	3.85	1.90	1.01	0.142	14.0
W 5x16	4.63	5.01	0.240	5.000	0.360	3.04	21.1	8.41	2.13	1.06	7.50	3.00	1.27	0.179	40.5
W 5x18.9	5.48	5.00	0.316	5.003	0.416	3.54	23.8	9.53	2.09	1.38	8.69	3.48	1.26	0.295	45.6
W 5x19	5.48	5.15	0.270	5.030	0.430	3.66	25.9	10.1	2.17	1.24	9.13	3.63	1.29	0.299	50.8
W 6x9	2.62	5.90	0.170	3.940	0.215	1.43	16.0	5.43	2.47	0.922	2.19	1.11	0.914	0.0362	17.7
W 6x12	3.50	6.03	0.230	4.000	0.280	1.91	21.7	7.19	2.49	1.27	2.99	1.50	0.925	0.0835	24.7
W 6x15	4.37	5.99	0.230	5.990	0.260	2.63	28.7	9.59	2.56	1.21	9.32	3.11	1.46	0.0958	76.4
W 6x16	4.69	6.28	0.260	4.030	0.405	2.78	31.8	10.1	2.60	1.50	4.43	2.20	0.972	0.214	38.1
W 6x20	5.82	6.20	0.260	6.020	0.365	3.71	41.0	13.2	2.65	1.43	13.3	4.41	1.51	0.233	113
W 6x25	7.28	6.38	0.320	6.080	0.455	4.68	53.0	16.6	2.70	1.81	17.1	5.61	1.53	0.452	150
W 8x10	2.89	7.89	0.170	3.940	0.205	1.37	29.8	7.55	3.21	1.26	2.09	1.06	0.851	0.036	30.9
W 8x13	3.76	7.99	0.230	4.000	0.255	1.74	38.5	9.65	3.20	1.71	2.73	1.36	0.852	0.0776	40.7
W 8x15	4.36	8.11	0.245	4.015	0.315	2.16	47.0	11.6	3.28	1.85	3.41	1.70	0.884	0.124	51.6
W 8x18	5.19	8.14	0.230	5.250	0.330	2.93	60.9	15.0	3.43	1.73	7.97	3.03	1.24	0.160	121
W 8x21	6.09	8.28	0.250	5.270	0.400	3.56	74.2	17.9	3.49	1.92	9.77	3.71	1.27	0.269	151
W 8x24	6.94	7.93	0.245	6.495	0.400	4.38	81.1	20.5	3.42	1.78	18.3	5.63	1.62	0.318	259
W 8x28	8.11	8.06	0.285	6.535	0.465	5.13	96.4	23.9	3.45	2.09	21.6	6.62	1.63	0.502	312
W 8x31	8.99	8.00	0.285	7.995	0.435	5.86	108	27.1	3.47	2.04	37.1	9.27	2.03	0.506	530
W 8x35	10.2	8.12	0.310	8.020	0.495	6.69	125	30.8	3.51	2.25	42.6	10.6	2.05	0.734	619
W 8x40	11.6	8.25	0.360	8.070	0.560	7.63	145	35.1	3.53	2.65	49.1	12.2	2.06	1.08	725
W 8x48	14.0	8.50	0.400	8.110	0.685	9.38	182	42.9	3.61	3.05	60.9	15.0	2.09	1.91	930

Copyright ©2007 by Stainless Structures, LLC

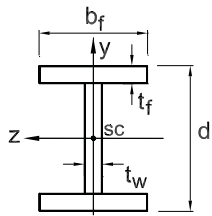

# W Shapes (Laser Fused)

## Dimensions and Properties

Shape	A	Web		Flange		Axis z-z				Axis y-y				Torsion Properties	
		d	t <sub>w</sub>	b <sub>f</sub>	t <sub>f</sub>	A <sub>z</sub>	I <sub>z</sub>	S <sub>z</sub>	r <sub>z</sub>	A <sub>y</sub>	I <sub>y</sub>	S <sub>y</sub>	r <sub>y</sub>	J	C <sub>w</sub>
		in. <sup>2</sup>	in.	in.	in.	in. <sup>2</sup>	in. <sup>4</sup>	in. <sup>3</sup>	in.	in. <sup>2</sup>	in. <sup>4</sup>	in. <sup>3</sup>	in.	in. <sup>4</sup>	in. <sup>6</sup>
W 8x58	17.0	8.75	0.510	8.220	0.810	11.3	226	51.7	3.65	3.97	75.1	18.3	2.10	3.27	1,182
W 8x67	19.5	9.00	0.570	8.280	0.935	13.2	270	60.0	3.72	4.57	88.6	21.4	2.13	4.98	1,438
W 10x12	3.46	9.87	0.190	3.960	0.210	1.41	52.2	10.6	3.88	1.77	2.18	1.10	0.794	0.0479	50.7
W 10x15	4.33	9.99	0.230	4.000	0.270	1.84	67.2	13.5	3.94	2.16	2.89	1.44	0.817	0.0943	68.0
W 10x17	4.91	10.11	0.240	4.010	0.330	2.26	80.2	15.9	4.04	2.29	3.56	1.77	0.851	0.144	84.8
W 10x19	5.54	10.24	0.250	4.020	0.395	2.70	94.6	18.5	4.13	2.42	4.29	2.13	0.880	0.219	104
W 10x22	6.41	10.17	0.240	5.750	0.360	3.49	117	22.9	4.26	2.28	11.4	3.97	1.33	0.229	274
W 10x26	7.53	10.33	0.260	5.770	0.440	4.29	143	27.6	4.35	2.52	14.1	4.89	1.37	0.390	344
W 10x30	8.76	10.47	0.300	5.810	0.510	5.01	168	32.1	4.38	2.94	16.7	5.75	1.38	0.607	413
W 10x33	9.49	9.73	0.290	7.960	0.435	5.83	166	34.2	4.19	2.57	36.6	9.19	1.96	0.522	790
W 10x39	11.3	9.92	0.315	7.985	0.530	7.13	205	41.3	4.27	2.86	45.0	11.3	2.00	0.900	991
W 10x45	13.0	10.10	0.350	8.020	0.620	8.38	244	48.3	4.33	3.24	53.3	13.3	2.02	1.42	1,198
W 10x49	14.2	9.98	0.340	10.000	0.560	9.42	268	53.8	4.35	3.04	93.4	18.7	2.56	1.31	2,071
W 10x54	15.6	10.09	0.370	10.030	0.615	10.4	299	59.2	4.37	3.35	103	20.6	2.57	1.74	2,321
W 10x60	17.4	10.22	0.420	10.080	0.680	11.6	337	65.9	4.40	3.84	116	23.0	2.58	2.37	2,641
W 10x68	19.8	10.40	0.470	10.130	0.770	13.2	390	74.9	4.44	4.37	133	26.4	2.60	3.44	3,093
W 10x77	22.4	10.60	0.530	10.190	0.870	15.0	451	85.2	4.49	5.01	154	30.1	2.62	4.98	3,631
W 10x88	25.7	10.84	0.605	10.265	0.990	17.2	530	97.7	4.54	5.84	179	34.8	2.64	7.37	4,329
W 12x14	4.08	11.91	0.200	3.970	0.225	1.52	86.1	14.5	4.59	2.26	2.35	1.19	0.760	0.0631	80.1
W 12x16	4.64	11.99	0.220	3.990	0.265	1.80	100	16.7	4.65	2.50	2.82	1.41	0.779	0.0935	96.4
W 12x19	5.50	12.16	0.235	4.005	0.350	2.39	127	20.9	4.81	2.72	3.76	1.88	0.827	0.169	131

Copyright ©2007 by Stainless Structures, LLC

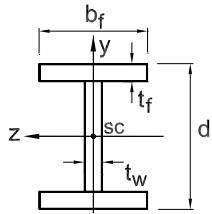

# W Shapes (Laser Fused)

## Dimensions and Properties

Shape	A	Web		Flange		Axis z-z				Axis y-y				Torsion Properties	
		d	t <sub>w</sub>	b <sub>f</sub>	t <sub>f</sub>	A <sub>z</sub>	I <sub>z</sub>	S <sub>z</sub>	r <sub>z</sub>	A <sub>y</sub>	I <sub>y</sub>	S <sub>y</sub>	r <sub>y</sub>	J	C <sub>w</sub>
		in. <sup>2</sup>	in.	in.	in.	in. <sup>2</sup>	in. <sup>4</sup>	in. <sup>3</sup>	in.	in. <sup>2</sup>	in. <sup>4</sup>	in. <sup>3</sup>	in.	in. <sup>4</sup>	in. <sup>6</sup>
W 12x22	6.41	12.31	0.260	4.030	0.425	2.92	154	25.0	4.90	3.05	4.65	2.31	0.852	0.279	164
W 12x26	7.57	12.22	0.230	6.490	0.380	4.15	202	33.0	5.16	2.65	17.3	5.34	1.51	0.291	607
W 12x30	8.72	12.34	0.260	6.520	0.440	4.84	236	38.2	5.20	3.02	20.3	6.24	1.53	0.446	720
W 12x35	10.3	12.50	0.300	6.560	0.520	5.76	283	45.2	5.25	3.53	24.5	7.47	1.55	0.729	878
W 12x40	11.5	11.94	0.295	8.050	0.515	6.98	303	50.7	5.13	3.28	44.8	11.1	1.97	0.841	1,461
W 12x45	12.9	12.06	0.335	8.045	0.575	7.80	342	56.6	5.14	3.75	49.9	12.4	1.97	1.18	1,645
W 12x50	14.4	12.19	0.370	8.080	0.640	8.73	385	63.2	5.18	4.19	56.3	13.9	1.98	1.62	1,877
W 12x53	15.3	12.06	0.345	9.995	0.575	9.67	417	69.1	5.23	3.81	95.7	19.2	2.50	1.44	3,155
W 12x58	16.7	12.19	0.360	10.010	0.640	10.8	467	76.6	5.28	4.03	107	21.4	2.53	1.95	3,568
W 12x65	18.8	12.12	0.390	12.000	0.605	12.2	524	86.5	5.28	4.24	174	29.0	3.05	2.03	5,776
W 12x72	20.8	12.25	0.430	12.040	0.670	13.6	588	96.0	5.31	4.72	195	32.4	3.06	2.76	6,534
W 12x79	22.9	12.38	0.470	12.080	0.735	15.0	654	106	5.34	5.21	216	35.8	3.07	3.65	7,321
W 12x87	25.3	12.53	0.515	12.125	0.810	16.6	731	117	5.38	5.77	241	39.7	3.09	4.89	8,264
W 12x96	27.9	12.71	0.550	12.160	0.900	18.5	824	130	5.44	6.26	270	44.4	3.11	6.65	9,404
W 12x106	31.2	12.89	0.610	12.400	0.990	20.7	937	145	5.48	7.02	315	50.8	3.18	9.01	11,137
W 14x22	6.36	13.74	0.230	5.000	0.335	2.84	193	28.1	5.51	3.01	6.99	2.80	1.05	0.184	314
W 14x26	7.55	13.91	0.255	5.025	0.420	3.58	240	34.4	5.63	3.38	8.90	3.54	1.09	0.328	404
W 14x30	8.71	13.84	0.270	6.730	0.385	4.37	285	41.2	5.72	3.52	19.6	5.82	1.50	0.351	885
W 14x34	9.86	13.98	0.285	6.745	0.455	5.18	334	47.8	5.82	3.77	23.3	6.91	1.54	0.538	1,064
W 14x38	11.0	14.10	0.310	6.770	0.515	5.89	380	53.8	5.87	4.13	26.7	7.88	1.56	0.762	1,229
W 14x43	12.3	13.66	0.305	7.995	0.530	7.14	416	61.0	5.81	3.91	45.2	11.3	1.91	0.929	1,946

Copyright ©2007 by Stainless Structures, LLC

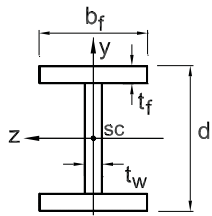

# W Shapes (Laser Fused)

## Dimensions and Properties

Shape	A	Web		Flange		Axis z-z				Axis y-y				Torsion Properties	
		d	t <sub>w</sub>	b <sub>f</sub>	t <sub>f</sub>	A <sub>z</sub>	I <sub>z</sub>	S <sub>z</sub>	r <sub>z</sub>	A <sub>y</sub>	I <sub>y</sub>	S <sub>y</sub>	r <sub>y</sub>	J	C <sub>w</sub>
		in.	in.	in.	in.	in. <sup>2</sup>	in. <sup>4</sup>	in. <sup>3</sup>	in.	in. <sup>2</sup>	in. <sup>4</sup>	in. <sup>3</sup>	in.	in. <sup>4</sup>	in. <sup>6</sup>
W 14x48	13.8	13.79	0.340	8.030	0.595	8.06	473	68.6	5.85	4.40	51.4	12.8	1.93	1.31	2,235
W 14x53	15.3	13.92	0.370	8.060	0.660	8.98	530	76.1	5.88	4.83	57.6	14.3	1.94	1.78	2,532
W 14x61	17.6	13.89	0.375	9.995	0.645	10.9	628	90.5	5.97	4.82	107	21.5	2.47	2.04	4,708
W 14x68	19.7	14.04	0.415	10.035	0.720	12.2	711	101	6.01	5.39	121	24.2	2.48	2.84	5,379
W 14x74	21.5	14.17	0.450	10.070	0.785	13.3	784	111	6.04	5.89	134	26.6	2.49	3.68	5,984
W 14x82	23.7	14.31	0.510	10.130	0.855	14.6	870	122	6.05	6.72	148	29.3	2.50	4.85	6,704
W 14x90	26.2	14.02	0.440	14.520	0.710	17.3	987	141	6.14	5.52	362	49.9	3.72	3.91	16,044
W 14x99	28.8	14.16	0.485	14.565	0.780	19.1	1,099	155	6.17	6.14	402	55.2	3.73	5.19	17,977
W 14x109	31.7	14.32	0.525	14.605	0.860	21.1	1,227	171	6.22	6.72	447	61.2	3.75	6.93	20,225
W 14x120	35.0	14.48	0.590	14.670	0.940	23.2	1,364	188	6.24	7.61	495	67.5	3.76	9.16	22,670
W 16x26	7.55	15.69	0.250	5.500	0.345	3.22	294	37.4	6.24	3.73	9.59	3.49	1.13	0.236	563
W 16x31	8.99	15.88	0.275	5.525	0.440	4.12	367	46.2	6.39	4.17	12.4	4.49	1.17	0.429	737
W 16x36	10.4	15.86	0.295	6.985	0.430	5.07	441	55.6	6.50	4.43	24.5	7.00	1.53	0.514	1,454
W 16x40	11.6	16.01	0.305	6.995	0.505	5.97	511	63.8	6.62	4.64	28.8	8.25	1.57	0.760	1,731
W 16x45	13.1	16.13	0.345	7.035	0.565	6.73	579	71.8	6.64	5.27	32.8	9.34	1.58	1.07	1,986
W 16x50	14.6	16.26	0.380	7.070	0.630	7.55	651	80.1	6.68	5.85	37.2	10.5	1.60	1.48	2,266
W 16x57	16.6	16.43	0.430	7.120	0.715	8.65	750	91.3	6.72	6.67	43.1	12.1	1.61	2.17	2,656
W 16x67	19.5	16.33	0.395	10.235	0.665	11.5	947	116	6.96	6.02	119	23.2	2.47	2.36	7,290
W 16x77	22.5	16.52	0.455	10.295	0.760	13.2	1,100	133	7.00	7.00	138	26.9	2.48	3.55	8,582
W 16x89	26.0	16.75	0.525	10.365	0.875	15.3	1,292	154	7.05	8.17	163	31.4	2.50	5.44	10,231
W 16x100	29.3	16.97	0.585	10.425	0.985	17.4	1,478	174	7.10	9.22	186	35.7	2.52	7.74	11,882

Copyright ©2007 by Stainless Structures, LLC

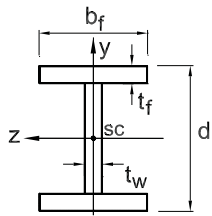

# W Shapes (Laser Fused)

## Dimensions and Properties

Shape	A	Web		Flange		Axis z-z				Axis y-y				Torsion Properties	
		d	t <sub>w</sub>	b <sub>f</sub>	t <sub>f</sub>	A <sub>z</sub>	I <sub>z</sub>	S <sub>z</sub>	r <sub>z</sub>	A <sub>y</sub>	I <sub>y</sub>	S <sub>y</sub>	r <sub>y</sub>	J	C <sub>w</sub>
		in.	in.	in.	in.	in. <sup>2</sup>	in. <sup>4</sup>	in. <sup>3</sup>	in.	in. <sup>2</sup>	in. <sup>4</sup>	in. <sup>3</sup>	in.	in. <sup>4</sup>	in. <sup>6</sup>
W 18x35	10.2	17.70	0.300	6.000	0.425	4.33	500	56.5	7.02	5.05	15.3	5.11	1.23	0.473	1,141
W 18x40	11.6	17.90	0.315	6.015	0.525	5.36	602	67.3	7.20	5.38	19.1	6.35	1.28	0.773	1,437
W 18x46	13.4	18.06	0.360	6.060	0.605	6.24	702	77.8	7.24	6.19	22.5	7.43	1.30	1.18	1,709
W 18x50	14.5	17.99	0.355	7.495	0.570	7.23	790	87.8	7.37	6.06	40.1	10.7	1.66	1.21	3,034
W 18x55	16.1	18.11	0.390	7.530	0.630	8.04	881	97.2	7.40	6.70	44.9	11.9	1.67	1.63	3,424
W 18x60	17.5	18.24	0.415	7.555	0.695	8.91	974	107	7.46	7.17	50.1	13.2	1.69	2.13	3,844
W 18x65	19.0	18.35	0.450	7.590	0.750	9.67	1,062	116	7.48	7.82	54.8	14.4	1.70	2.69	4,233
W 18x71	20.7	18.47	0.495	7.635	0.810	10.5	1,162	126	7.49	8.64	60.3	15.8	1.71	3.44	4,685
W 18x76	22.2	18.21	0.425	11.035	0.680	12.6	1,323	145	7.73	7.23	152	27.6	2.62	2.81	11,700
W 18x86	25.2	18.39	0.480	11.090	0.770	14.4	1,518	165	7.77	8.24	175	31.6	2.64	4.08	13,586
W 18x97	28.4	18.59	0.535	11.145	0.870	16.4	1,737	187	7.82	9.27	201	36.1	2.66	5.86	15,757
W 18x106	31.0	18.73	0.590	11.200	0.940	17.8	1,903	203	7.83	10.3	220	39.4	2.67	7.50	17,415
W 21x44	12.8	20.66	0.350	6.500	0.450	4.99	822	79.6	8.03	6.87	20.7	6.36	1.27	0.700	2,103
W 21x50	14.5	20.83	0.380	6.530	0.535	5.96	964	92.6	8.15	7.53	24.9	7.63	1.31	1.06	2,557
W 21x57	16.5	21.06	0.405	6.555	0.650	7.27	1,148	109	8.34	8.13	30.6	9.34	1.36	1.68	3,178
W 21x62	18.0	20.99	0.400	8.240	0.615	8.59	1,309	125	8.52	7.98	57.5	13.9	1.78	1.75	5,952
W 21x68	19.8	21.13	0.430	8.270	0.685	9.61	1,461	138	8.58	8.63	64.7	15.6	1.81	2.35	6,748
W 21x73	21.3	21.24	0.455	8.295	0.740	10.4	1,583	149	8.63	9.17	70.5	17.0	1.82	2.92	7,396
W 21x83	24.1	21.43	0.515	8.333	0.835	11.8	1,808	169	8.66	10.5	80.8	19.4	1.83	4.22	8,539
W 21x93	27.1	21.62	0.580	8.420	0.930	13.4	2,050	190	8.69	11.9	92.8	22.1	1.85	5.92	9,902
W 21x101	29.5	21.36	0.500	12.290	0.800	16.6	2,401	225	9.01	10.0	248	40.3	2.90	5.14	26,157

Copyright ©2007 by Stainless Structures, LLC

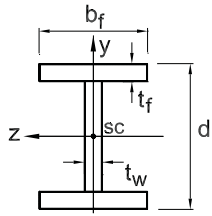

# W Shapes (Laser Fused)

## Dimensions and Properties

Shape	A	Web		Flange		Axis z-z				Axis y-y				Torsion Properties	
		d	t <sub>w</sub>	b <sub>f</sub>	t <sub>f</sub>	A <sub>z</sub>	I <sub>z</sub>	S <sub>z</sub>	r <sub>z</sub>	A <sub>y</sub>	I <sub>y</sub>	S <sub>y</sub>	r <sub>y</sub>	J	C <sub>w</sub>
		in. <sup>2</sup>	in.	in.	in.	in. <sup>2</sup>	in. <sup>4</sup>	in. <sup>3</sup>	in.	in. <sup>2</sup>	in. <sup>4</sup>	in. <sup>3</sup>	in.	in. <sup>4</sup>	in. <sup>6</sup>
W 21x111	32.5	21.51	0.550	12.340	0.875	18.2	2,654	247	9.04	11.1	274	44.5	2.91	6.76	29,171
W 21x122	35.6	21.68	0.600	12.390	0.960	20.1	2,941	271	9.08	12.2	305	49.2	2.92	8.91	32,663
W 24x55	16.0	23.57	0.395	7.000	0.505	6.04	1,318	112	9.08	8.85	29.0	8.28	1.35	1.10	3,840
W 24x62	18.0	23.74	0.430	7.040	0.590	7.10	1,525	128	9.20	9.71	34.5	9.79	1.38	1.61	4,597
W 24x68	19.9	23.73	0.415	8.965	0.585	8.88	1,802	152	9.53	9.36	70.4	15.7	1.88	1.79	9,408
W 24x76	22.2	23.92	0.440	8.990	0.680	10.4	2,072	173	9.67	10.0	82.5	18.4	1.93	2.60	11,119
W 24x84	24.5	24.10	0.470	9.020	0.770	11.8	2,341	194	9.78	10.8	94.4	20.9	1.96	3.60	12,815
W 24x94	27.5	24.31	0.515	9.065	0.875	13.5	2,672	220	9.86	11.9	109	24.0	1.99	5.16	14,915
W 24x104	30.4	24.06	0.500	12.750	0.750	16.1	3,077	256	10.1	11.3	259	40.7	2.92	4.66	35,194
W 24x117	34.2	24.26	0.550	12.800	0.850	18.4	3,509	289	10.1	12.5	297	46.5	2.95	6.66	40,704
W 24x131	38.3	24.48	0.605	12.855	0.960	20.9	3,994	326	10.2	13.9	340	52.9	2.98	9.47	47,006

# Part 1

## S Shapes Dimensions and Properties

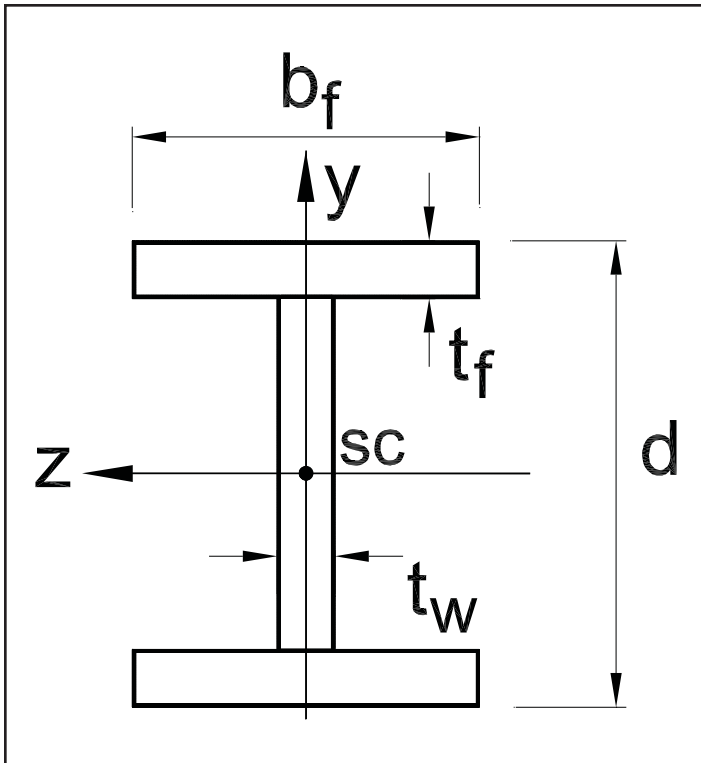

### DIMENSIONS AND PROPERTIES OF LASER-FUSED AND HOT-ROLLED S SHAPES

Dimensions and properties of laser-fused and hot-rolled S shapes are given in this section. The following notations are used in these tables.

- $A$  Gross cross sectional area of the section
- $d$  Full nominal depth of the section
- $t_w$  Web thickness
- $b_f$  Flange width
- $t_f$  Flange thickness
- $A_z$  Shear area with respect to the principal axis  $z$
- $I_z$  Moment of inertia about the principal axis  $z$
- $S_z$  Elastic section modulus corresponding to the principal axis  $z$
- $r_z$  Radius of gyration corresponding to the principal axis  $z$
- $A_y$  Shear area with respect to the principal axis  $y$
- $I_y$  Moment of inertia about the principal axis  $y$
- $S_y$  Elastic section modulus corresponding to the principal axis  $y$
- $r_y$  Radius of gyration corresponding to the principal axis  $y$
- $J$  Torsion constant
- $C_w$  Warping constant
- $SC$  Shear center

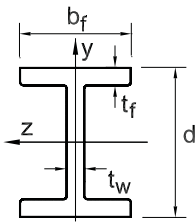

# S Shapes (Laser Fused)

## Dimensions and Properties

Shape	A	Web		Flange		Axis z-z				Axis y-y				Torsion Properties	
		d	t <sub>w</sub>	b <sub>f</sub>	t <sub>f</sub>	A <sub>z</sub>	I <sub>z</sub>	S <sub>z</sub>	r <sub>z</sub>	A <sub>y</sub>	I <sub>y</sub>	S <sub>y</sub>	r <sub>y</sub>	J	C <sub>w</sub>
		in. <sup>2</sup>	in.	in.	in.	in. <sup>2</sup>	in. <sup>4</sup>	in. <sup>3</sup>	in.	in. <sup>2</sup>	in. <sup>4</sup>	in. <sup>3</sup>	in.	in. <sup>4</sup>	in. <sup>6</sup>
S 3x7.50	2.17	3.00	0.349	2.509	0.260	1.19	2.90	1.93	1.16	0.893	0.693	0.553	0.565	0.0709	1.28
S 4x9.50	2.75	4.00	0.326	2.796	0.293	1.45	6.72	3.36	1.56	1.15	1.08	0.771	0.626	0.0925	3.67
S 5x14.75	4.29	5.00	0.494	3.284	0.326	2.01	15.1	6.04	1.88	2.17	1.97	1.20	0.677	0.275	10.5
S 6x17.3	5.02	6.00	0.465	3.565	0.359	2.33	26.1	8.70	2.28	2.49	2.76	1.55	0.741	0.310	21.6
S 7x15.3	4.44	7.00	0.252	3.662	0.392	2.45	36.4	10.4	2.86	1.64	3.22	1.76	0.851	0.183	35.0
S 7x20.0	5.82	7.00	0.450	3.860	0.392	2.70	42.1	12.0	2.69	2.85	3.80	1.97	0.808	0.367	41.0
S 8x18.4	5.34	8.00	0.271	4.001	0.425	2.90	57.1	14.3	3.27	2.03	4.55	2.27	0.923	0.257	65.1
S 8x23.0	6.70	8.00	0.441	4.171	0.425	3.13	64.3	16.1	3.10	3.22	5.19	2.49	0.880	0.441	73.7
S 10x25.4	7.38	10.00	0.311	4.661	0.491	3.90	123	24.5	4.07	2.92	8.31	3.57	1.06	0.467	187
S 10x35.0	10.2	10.00	0.594	4.944	0.491	4.38	146	29.2	3.78	5.41	10.0	4.06	0.992	1.09	224
S 12x31.8	9.26	12.00	0.350	5.000	0.544	4.65	217	36.1	4.84	3.96	11.4	4.55	1.11	0.707	372
S 12x35.0	10.2	12.00	0.428	5.078	0.544	4.78	228	38.0	4.73	4.80	11.9	4.70	1.08	0.857	390
S 12x40.8	12.0	12.00	0.472	5.252	0.659	5.98	271	45.1	4.76	5.28	16.0	6.09	1.16	1.41	512
S 12x50.0	14.6	12.00	0.687	5.477	0.659	6.49	302	50.4	4.56	7.56	18.3	6.69	1.12	2.33	580
S 15x42.9	12.5	15.00	0.411	5.501	0.622	5.87	443	59.1	5.95	5.82	17.3	6.30	1.18	1.23	892
S 15x50.0	14.6	15.00	0.550	5.640	0.622	6.15	482	64.3	5.75	7.70	18.8	6.66	1.14	1.74	961

Copyright ©2007 by Stainless Structures, LLC

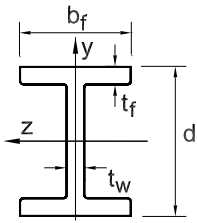

# S Shapes (Hot Rolled)

## Dimensions and Properties

Shape	A	Web		Flange		Axis z-z				Axis y-y				Torsion Properties	
		d	t <sub>w</sub>	b <sub>f</sub>	t <sub>f</sub>	A <sub>z</sub>	I <sub>z</sub>	S <sub>z</sub>	r <sub>z</sub>	A <sub>y</sub>	I <sub>y</sub>	S <sub>y</sub>	r <sub>y</sub>	J	C <sub>w</sub>
		in. <sup>2</sup>	in.	in.	in.	in. <sup>2</sup>	in. <sup>4</sup>	in. <sup>3</sup>	in.	in. <sup>2</sup>	in. <sup>4</sup>	in. <sup>3</sup>	in.	in. <sup>4</sup>	in. <sup>6</sup>
S 3x5.7	1.63	3.00	0.170	2.330	0.260	1.03	2.50	1.66	1.24	0.460	0.549	0.471	0.580	0.0318	1.03
S 3x7.5	2.17	3.00	0.349	2.509	0.260	1.19	2.90	1.93	1.16	0.893	0.693	0.553	0.565	0.0709	1.28
S 4x7.7	2.22	4.00	0.193	2.663	0.293	1.33	6.01	3.01	1.65	0.706	0.924	0.694	0.645	0.0541	3.17
S 4x9.5	2.75	4.00	0.326	2.796	0.293	1.45	6.72	3.36	1.56	1.15	1.08	0.771	0.626	0.0925	3.67
S 5x10	2.89	5.00	0.214	3.004	0.326	1.67	12.2	4.87	2.05	0.987	1.48	0.983	0.715	0.0851	8.04
S 5x14.75	4.29	5.00	0.494	3.284	0.326	2.01	15.1	6.04	1.88	2.17	1.97	1.20	0.677	0.275	10.5
S 6x12.5	3.62	6.00	0.232	3.332	0.359	2.04	21.9	7.30	2.46	1.29	2.22	1.33	0.783	0.127	17.6

# Part 1

## C Shapes Dimensions and Properties

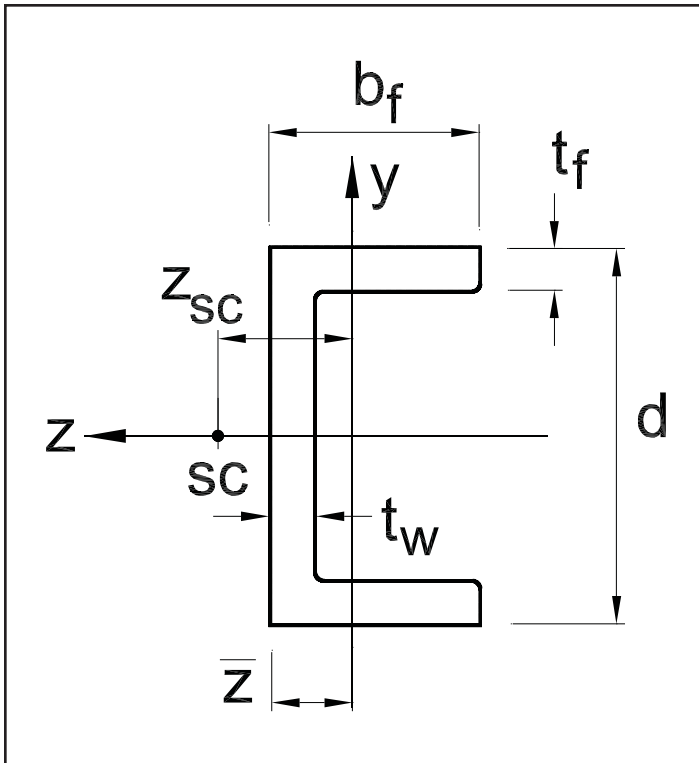

### DIMENSIONS AND PROPERTIES OF LASER-FUSED AND HOT-ROLLED CHANNELS

Dimensions and properties of laser-fused and hot-rolled channels or C shapes are given in this section. The following notations are used in these tables.

- $A$  Gross cross sectional area of the section
- $d$  Full nominal depth of the section
- $t_w$  Web thickness
- $b_f$  Flange width
- $t_f$  Flange thickness
- $A_z$  Shear area with respect to the principal axis  $z$
- $I_z$  Moment of inertia about the principal axis  $z$
- $S_z$  Elastic section modulus corresponding to the principal axis  $z$
- $r_z$  Radius of gyration corresponding to the principal axis  $z$
- $A_y$  Shear area with respect to the principal axis  $y$
- $I_y$  Moment of inertia about the principal axis  $y$
- $S_y^{\text{top}}$  Positive  $z$ -direction elastic section modulus corresponding to the principal axis  $y$
- $S_y^{\text{bot}}$  Negative  $z$ -direction elastic section modulus corresponding to the principal axis  $y$
- $r_y$  Radius of gyration corresponding to the principal axis  $y$
- $\bar{z}$  Location of the centroid
- $z_{sc}$   $z$ -coordinate of the shear center
- $J$  Torsion constant
- $C_w$  Warping constant
- $SC$  Shear center

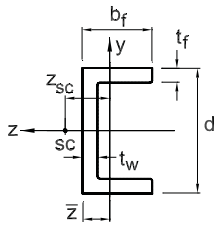

# C Shapes (Laser Fused)

## Dimensions and Properties

Shape	A	Web		Flange		Axis z-z				Axis y-y					Shear Center	Torsion Properties		
		d	t <sub>w</sub>	b <sub>f</sub>	t <sub>f</sub>	A <sub>z</sub>	I <sub>z</sub>	S <sub>z</sub>	r <sub>z</sub>	A <sub>y</sub>	I <sub>y</sub>	S <sub>y</sub> <sup>top</sup>	S <sub>y</sub> <sup>bot</sup>	r <sub>y</sub>	$\bar{z}$	z <sub>sc</sub>	J	C <sub>w</sub>
		in.	in.	in.	in.	in. <sup>2</sup>	in. <sup>4</sup>	in. <sup>3</sup>	in.	in. <sup>2</sup>	in. <sup>4</sup>	in. <sup>3</sup>	in. <sup>3</sup>	in.	in.	in.	in. <sup>4</sup>	in. <sup>6</sup>
C 3x5.0	1.45	3.00	0.258	1.498	0.273	0.519	1.84	1.23	1.13	0.625	0.294	0.614	0.288	0.450	0.478	0.849	0.0356	0.373
C 3x6.0	1.75	3.00	0.356	1.596	0.273	0.607	2.06	1.38	1.09	0.839	0.362	0.742	0.327	0.455	0.488	0.782	0.0642	0.454
C 6x13.0	3.80	6.00	0.437	2.157	0.343	0.864	17.3	5.77	2.13	2.24	1.28	2.31	0.798	0.580	0.553	0.913	0.223	7.16
C 7x9.8	2.85	7.00	0.210	2.090	0.366	0.626	21.2	6.05	2.73	1.33	1.19	1.94	0.802	0.646	0.610	1.25	0.0883	9.06
C 7x12.25	3.57	7.00	0.314	2.194	0.366	0.759	24.1	6.89	2.60	1.94	1.44	2.49	0.893	0.635	0.579	1.10	0.142	11.1
C 7x14.75	4.31	7.00	0.419	2.299	0.366	0.899	27.1	7.75	2.51	2.55	1.69	2.92	0.979	0.625	0.577	1.00	0.244	13.1
C 8x11.5	3.35	8.00	0.220	2.260	0.390	0.684	32.4	8.11	3.11	1.60	1.63	2.51	1.01	0.697	0.647	1.33	0.116	16.4
C 8x13.75	4.02	8.00	0.303	2.343	0.390	0.800	36.0	9.00	2.99	2.16	1.89	3.07	1.09	0.686	0.616	1.21	0.165	19.1
C 8x18.75	5.49	8.00	0.487	2.527	0.390	1.07	43.8	11.0	2.83	3.39	2.43	3.99	1.27	0.666	0.610	1.02	0.406	25.0
C 9x13.4	3.91	9.00	0.233	2.433	0.413	0.750	47.7	10.6	3.49	1.91	2.18	3.20	1.25	0.747	0.681	1.41	0.151	28.0
C 9x15.0	4.38	9.00	0.285	2.485	0.413	0.828	50.8	11.3	3.41	2.31	2.39	3.64	1.31	0.739	0.658	1.33	0.183	30.8
C 9x20.0	5.85	9.00	0.448	2.648	0.413	1.07	60.7	13.5	3.22	3.55	3.00	4.72	1.49	0.716	0.635	1.13	0.391	39.2
C 10x15.3	4.46	10.00	0.240	2.600	0.436	0.811	67.1	13.4	3.88	2.20	2.84	3.94	1.51	0.798	0.720	1.51	0.188	45.2
C 10x20.0	5.85	10.00	0.379	2.739	0.436	1.03	78.7	15.7	3.67	3.39	3.50	5.22	1.69	0.774	0.671	1.29	0.332	56.6
C 10x25.0	7.32	10.00	0.526	2.886	0.436	1.27	90.9	18.2	3.52	4.63	4.16	6.21	1.87	0.754	0.669	1.15	0.643	68.0
C 10x30.0	8.79	10.00	0.673	3.033	0.436	1.55	103	20.6	3.43	5.86	4.83	6.99	2.06	0.742	0.692	1.04	1.19	79.2
C 12x20.7	6.05	12.00	0.282	2.942	0.501	1.01	129	21.5	4.61	3.11	4.82	6.11	2.24	0.893	0.789	1.65	0.334	111
C 12x25.0	7.31	12.00	0.387	3.047	0.501	1.20	144	24.0	4.44	4.20	5.56	7.42	2.42	0.872	0.749	1.48	0.485	130
C 12x30.0	8.79	12.00	0.510	3.170	0.501	1.42	162	26.9	4.29	5.46	6.37	8.65	2.62	0.851	0.736	1.34	0.787	151
C 15x33.9	9.90	15.00	0.400	3.400	0.650	1.46	313	41.8	5.63	5.50	9.84	11.3	3.89	0.997	0.870	1.75	0.940	355
C 15x40.0	11.7	15.00	0.520	3.520	0.650	1.72	347	46.3	5.45	7.06	11.2	13.2	4.17	0.976	0.847	1.60	1.33	408
C 15x50.0	14.6	15.00	0.716	3.716	0.650	2.18	402	53.6	5.24	9.58	13.3	15.5	4.63	0.952	0.853	1.41	2.50	490

Copyright ©2007 by Stainless Structures, LLC

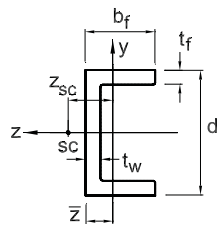

# C Shapes (Hot Rolled)

## Dimensions and Properties

Shape	A	Web		Flange		Axis z-z				Axis y-y					Shear Center	Torsion Properties		
		d	t <sub>w</sub>	b <sub>f</sub>	t <sub>f</sub>	A <sub>z</sub>	I <sub>z</sub>	S <sub>z</sub>	r <sub>z</sub>	A <sub>y</sub>	I <sub>y</sub>	S <sub>y</sub> <sup>top</sup>	S <sub>y</sub> <sup>bot</sup>	r <sub>y</sub>	$\bar{z}$	z <sub>sc</sub>	J	C <sub>w</sub>
		in.	in.	in.	in.	in. <sup>2</sup>	in. <sup>4</sup>	in. <sup>3</sup>	in.	in. <sup>2</sup>	in. <sup>4</sup>	in. <sup>3</sup>	in. <sup>3</sup>	in.	in.	in.	in. <sup>4</sup>	in. <sup>6</sup>
C 3x4.1	1.19	3.00	0.170	1.410	0.273	0.449	1.65	1.10	1.18	0.428	0.233	0.477	0.252	0.443	0.487	0.931	0.0223	0.301
C 3x5.0	1.45	3.00	0.258	1.498	0.273	0.518	1.84	1.23	1.13	0.624	0.294	0.614	0.288	0.450	0.478	0.850	0.0351	0.373
C 3x6.0	1.75	3.00	0.356	1.596	0.273	0.604	2.06	1.38	1.09	0.837	0.362	0.742	0.327	0.455	0.488	0.782	0.0626	0.454
C 4x5.4	1.56	4.00	0.184	1.584	0.296	0.486	3.83	1.92	1.56	0.637	0.382	0.747	0.356	0.494	0.511	0.999	0.0334	0.907
C 4x7.25	2.11	4.00	0.321	1.721	0.296	0.616	4.56	2.28	1.47	1.07	0.519	1.043	0.425	0.496	0.498	0.864	0.0699	1.22
C 5x6.7	1.95	5.00	0.190	1.750	0.320	0.525	7.45	2.98	1.96	0.839	0.578	1.064	0.479	0.545	0.543	1.08	0.0467	2.19
C 5x9.0	2.62	5.00	0.325	1.885	0.320	0.668	8.86	3.54	1.84	1.39	0.766	1.470	0.562	0.540	0.521	0.932	0.0935	2.90
C 6x8.2	2.38	6.00	0.200	1.920	0.343	0.572	13.1	4.35	2.34	1.07	0.843	1.464	0.627	0.595	0.576	1.16	0.0639	4.68
C 6x10.5	3.06	6.00	0.314	2.034	0.343	0.706	15.1	5.03	2.22	1.64	1.06	1.926	0.711	0.587	0.549	1.02	0.112	5.88
C 8x18.75	5.49	8.00	0.487	2.527	0.390	1.06	43.8	11.0	2.83	3.39	2.43	3.988	1.27	0.666	0.610	1.02	0.396	25.0

# Part 1

## T Shapes Dimensions and Properties

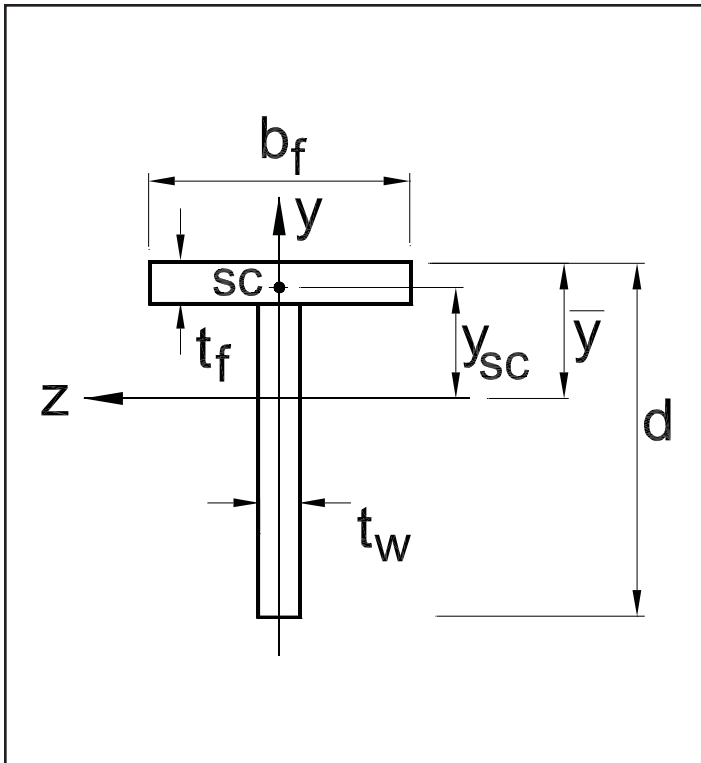

### DIMENSIONS AND PROPERTIES OF LASER-FUSED AND HOT-ROLLED T SHAPES

Dimensions and properties of laser-fused and hot-rolled T shapes are given in this section. The following notations are used in these tables.

- $A$  Gross cross sectional area of the section
- $d$  Full nominal depth of the section
- $t_w$  Web thickness
- $b_f$  Flange width
- $t_f$  Flange thickness
- $A_z$  Shear area with respect to the principal axis  $z$
- $I_z$  Moment of inertia about the principal axis  $z$
- $S_z^{\text{top}}$  Positive  $y$ -direction elastic section modulus corresponding to the principal axis  $z$
- $S_z^{\text{bot}}$  Negative  $y$ -direction elastic section modulus corresponding to the principal axis  $z$
- $r_z$  Radius of gyration corresponding to the principal axis  $z$
- $\bar{y}$  Location of the centroid
- $A_y$  Shear area with respect to the principal axis  $y$
- $I_y$  Moment of inertia about the principal axis  $y$
- $S_y$  Elastic section modulus corresponding to the principal axis  $y$
- $r_y$  Radius of gyration corresponding to the principal axis  $y$
- $y_{sc}$   $y$ -coordinate of the shear center
- $J$  Torsion constant
- $C_w$  Warping constant
- $SC$  Shear center

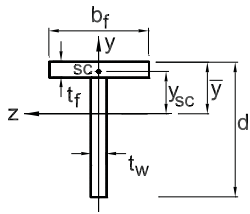

# T Shapes (Laser Fused)

# Dimensions and Properties

Shape	A	Web		Flange		Axis z-z						Axis y-y				Shear Center	Torsion Properties	
		d	t <sub>w</sub>	b <sub>f</sub>	t <sub>f</sub>	A <sub>z</sub>	I <sub>z</sub>	S <sub>z</sub> <sup>top</sup>	S <sub>z</sub> <sup>bot</sup>	r <sub>z</sub>	y	A <sub>y</sub>	I <sub>y</sub>	S <sub>y</sub>	r <sub>y</sub>	y <sub>sc</sub>	J	C <sub>w</sub>
		in. <sup>2</sup>	in.	in.	in.	in. <sup>2</sup>	in. <sup>4</sup>	in. <sup>3</sup>	in. <sup>3</sup>	in.	in.	in. <sup>2</sup>	in. <sup>4</sup>	in. <sup>3</sup>	in.	in.	in. <sup>4</sup>	in. <sup>6</sup>
T 3/4x3/4x 3/16	0.246	0.750	0.187	0.750	0.187	0.139	0.0116	0.0458	0.0235	0.218	0.254	0.119	0.0069	0.0183	0.167	0.126	0.0030	0.0001
T 1x1x3/16	0.339	1.000	0.187	1.000	0.187	0.176	0.0299	0.0941	0.0438	0.297	0.318	0.152	0.0160	0.0321	0.217	0.196	0.0042	0.0002
T 1-1/2x 1-1/2x3/16	0.339	1.500	0.187	1.500	0.187	0.251	0.110	0.247	0.104	0.457	0.444	0.223	0.0533	0.0711	0.318	0.330	0.0065	0.0007
T 1-1/2x 1-1/2x1/4	0.688	1.500	0.250	1.500	0.250	0.347	0.139	0.297	0.134	0.449	0.466	0.302	0.0719	0.096	0.323	0.306	0.0151	0.0015
T 1-3/4x 1-3/4x3/16	0.620	1.750	0.187	1.750	0.187	0.289	0.179	0.353	0.144	0.537	0.506	0.259	0.0844	0.096	0.369	0.395	0.0076	0.0011
T 2x2x3/16	0.713	2.000	0.187	2.000	0.187	0.328	0.272	0.478	0.190	0.617	0.569	0.295	0.126	0.126	0.420	0.460	0.0087	0.0016
T 2x2x1/4	0.938	2.000	0.250	2.000	0.250	0.448	0.348	0.587	0.247	0.609	0.592	0.397	0.169	0.169	0.425	0.440	0.0206	0.0037
T 2-1/2x 2-1/2x1/4	1.19	2.500	0.250	2.500	0.250	0.550	0.703	0.981	0.394	0.769	0.717	0.494	0.328	0.263	0.526	0.570	0.0261	0.0075
T 3x3x1/4	1.44	3.000	0.250	3.000	0.250	0.653	1.24	1.48	0.577	0.930	0.842	0.591	0.566	0.377	0.628	0.699	0.0315	0.0132
T 3x3x3/8	2.11	3.000	0.375	3.000	0.375	1.01	1.76	1.98	0.833	0.913	0.888	0.895	0.855	0.570	0.637	0.659	0.105	0.0425
T 4x4x1/4	1.94	4.000	0.250	4.000	0.250	0.859	3.04	2.78	1.05	1.25	1.09	0.786	1.34	0.669	0.831	0.953	0.0424	0.0322
T 4x4x3/8	2.86	4.000	0.375	4.000	0.375	1.32	4.36	3.83	1.52	1.23	1.14	1.18	2.02	1.01	0.840	0.919	0.142	0.105
T 5x5x1/4	2.44	5.000	0.250	5.000	0.250	1.07	6.05	4.50	1.65	1.57	1.34	0.981	2.61	1.04	1.03	1.21	0.0533	0.0638
T 5x5x3/8	3.61	5.000	0.375	5.000	0.375	1.62	8.74	6.30	2.42	1.56	1.39	1.48	3.93	1.57	1.04	1.18	0.179	0.209
T 5x5x1/2	4.75	5.000	0.500	5.000	0.500	2.20	11.3	7.84	3.16	1.54	1.43	1.98	5.26	2.10	1.05	1.14	0.418	0.481
T 6x6x1/4	2.94	6.000	0.250	6.000	0.250	1.27	10.6	6.64	2.40	1.90	1.59	1.18	4.51	1.50	1.24	1.46	0.0642	0.111
T 6x6x3/8	4.36	6.000	0.375	6.000	0.375	1.93	15.4	9.39	3.53	1.88	1.64	1.77	6.77	2.26	1.25	1.43	0.216	0.367

Copyright ©2007 by Stainless Structures, LLC

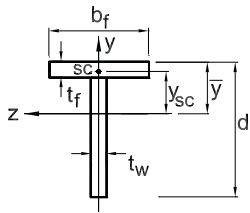

# T Shapes (Laser Fused)

## Dimensions and Properties

Shape	A	Web		Flange		Axis z-z						Axis y-y				Shear Center	Torsion Properties	
		d	t <sub>w</sub>	b <sub>f</sub>	t <sub>f</sub>	A <sub>z</sub>	I <sub>z</sub>	S <sub>z</sub> <sup>top</sup>	S <sub>z</sub> <sup>bot</sup>	r <sub>z</sub>	y	A <sub>y</sub>	I <sub>y</sub>	S <sub>y</sub>	r <sub>y</sub>	y <sub>sc</sub>	J	C <sub>w</sub>
		in. <sup>2</sup>	in.	in.	in.	in. <sup>2</sup>	in. <sup>4</sup>	in. <sup>3</sup>	in. <sup>3</sup>	in.	in.	in. <sup>2</sup>	in. <sup>4</sup>	in. <sup>3</sup>	in.	in.	in. <sup>4</sup>	in. <sup>6</sup>
T 6x6x1/2	5.75	6.000	0.500	6.000	0.500	2.61	19.9	11.8	4.61	1.86	1.68	2.36	9.06	3.02	1.26	1.40	0.505	0.848
T 7x7x1/4	3.44	7.000	0.250	7.000	0.250	1.48	16.9	9.19	3.29	2.22	1.84	1.37	7.15	2.04	1.44	1.71	0.0752	0.178
T 7x7x3/8	5.11	7.000	0.375	7.000	0.375	2.24	24.8	13.1	4.84	2.20	1.89	2.06	10.7	3.07	1.45	1.68	0.252	0.589
T 7x7x1/2	6.75	7.000	0.500	7.000	0.500	3.02	32.2	16.6	6.35	2.18	1.94	2.75	14.4	4.10	1.46	1.65	0.592	1.37
T 8x8x1/4	3.94	8.000	0.250	8.000	0.250	1.69	25.5	12.2	4.31	2.54	2.09	1.57	10.7	2.67	1.65	1.96	0.0861	0.268
T 8x8x3/8	5.86	8.000	0.375	8.000	0.375	2.56	37.3	17.4	6.37	2.52	2.14	2.36	16.0	4.01	1.65	1.94	0.289	0.886
T 8x8x1/2	7.75	8.000	0.500	8.000	0.500	3.44	48.6	22.3	8.36	2.50	2.19	3.14	21.4	5.35	1.66	1.91	0.680	2.06

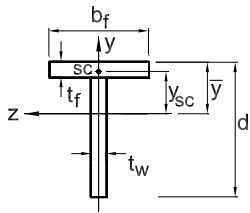

# T Shapes (Hot Rolled)

## Dimensions and Properties

Shape	A	Web		Flange		Axis z-z						Axis y-y				Shear Center	Torsional Properties	
		d	t <sub>w</sub>	b <sub>f</sub>	t <sub>f</sub>	A <sub>z</sub>	I <sub>z</sub>	S <sub>z</sub> <sup>top</sup>	S <sub>z</sub> <sup>bot</sup>	r <sub>z</sub>	y	A <sub>y</sub>	I <sub>y</sub>	S <sub>y</sub>	r <sub>y</sub>	y <sub>sc</sub>	J	C <sub>w</sub>
		in. <sup>2</sup>	in.	in.	in.	in. <sup>2</sup>	in. <sup>4</sup>	in. <sup>3</sup>	in. <sup>3</sup>	in.	in.	in. <sup>2</sup>	in. <sup>4</sup>	in. <sup>3</sup>	in.	in.	in. <sup>4</sup>	in. <sup>6</sup>
T 2x2x1/4	0.94	2.000	0.250	2.000	0.250	0.448	0.348	0.587	0.247	0.609	0.592	0.397	0.169	0.169	0.425	0.440	0.0206	0.0037

# Part 1

## L Shapes Equal Legs Dimensions and Properties (Principal Axes y,z)

### DIMENSIONS AND PROPERTIES OF EQUAL LEG SINGLE ANGLE SHAPES

Dimensions and properties of equal leg single angle shapes according to principal axes y,z are given in this section. The following notations are used in these tables.

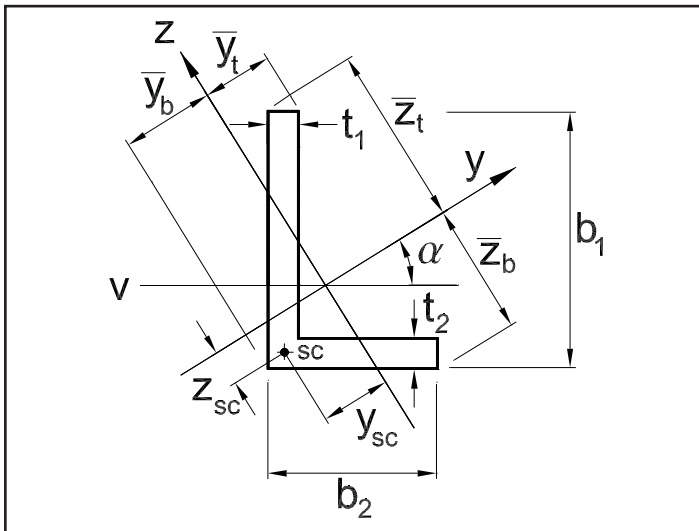

- A** Gross cross sectional area of the section
- b<sub>1</sub>** Full nominal length of leg 1
- t<sub>1</sub>** Leg 1 thickness
- b<sub>2</sub>** Full nominal length of leg 2
- t<sub>2</sub>** Leg 2 thickness
- α** Principal angle
- A<sub>y</sub>** Shear area with respect to the principal axis y
- I<sub>y</sub>** Moment of inertia about the principal axis y
- S<sub>y</sub><sup>top</sup>** Positive z-direction elastic section modulus corresponding to the principal axis y
- S<sub>y</sub><sup>bot</sup>** Negative z-direction elastic section modulus corresponding to the principal axis y
- r<sub>y</sub>** Radius of gyration corresponding to the principal axis y
- z<sub>t</sub>** Positive z direction distance from the centroid to the extreme fiber
- z<sub>b</sub>** Negative z direction distance from the centroid to the extreme fiber
- A<sub>z</sub>** Shear area with respect to the principal axis z
- I<sub>z</sub>** Moment of inertia about the principal axis z
- S<sub>z</sub><sup>top</sup>** Positive y-direction elastic section modulus corresponding to the principal axis z
- S<sub>z</sub><sup>bot</sup>** Negative y-direction elastic section modulus corresponding to the principal axis z
- r<sub>z</sub>** Radius of gyration corresponding to the principal axis z
- y<sub>t</sub>** Positive y direction distance from the centroid to the extreme fiber
- y<sub>b</sub>** Negative y direction distance from the centroid to the extreme fiber
- y<sub>sc</sub>** y-coordinate of the shear center
- z<sub>sc</sub>** z-coordinate of the shear center
- J** Torsion constant
- C<sub>w</sub>** Warping constant
- SC** Shear center

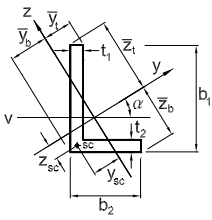

# L Shapes EQUAL LEGS (Principal Axes y, z)

## Dimensions and Properties

Shape	A	Leg1		Leg2		$\alpha$	Axis y-y						Axis z-z						Shear Center		Torsion Properties			
		$b_1$	$t_1$	$b_2$	$t_2$		$A_y$	$I_y$	$S_y^{top}$	$S_y^{bot}$	$r_y$	$\bar{z}_t$	$\bar{z}_b$	$A_z$	$I_z$	$S_z^{top}$	$S_z^{bot}$	$r_z$	$\bar{y}_t$	$\bar{y}_b$	$y_{sc}$	$z_{sc}$	J	$C_w$
		in. <sup>2</sup>	in.	in.	in.		in.	deg.	in. <sup>2</sup>	in. <sup>4</sup>	in. <sup>3</sup>	in. <sup>3</sup>	in.	in.	in.	in. <sup>2</sup>	in. <sup>4</sup>	in. <sup>3</sup>	in. <sup>3</sup>	in.	in.	in.	in.	in.
L 1/2-1/2x1/8	0.109	0.50	0.1250	0.50	0.1250	45.0	0.0577	0.0036	0.0101	0.0101	0.180	0.354	0.354	0.0541	0.0011	0.0052	0.0044	0.0979	0.202	0.240	-0.137	0.0	0.0006	0.0000
L 3/4-3/4x1/8	0.172	0.75	0.1250	0.75	0.1250	45.0	0.0799	0.0137	0.0257	0.0257	0.282	0.530	0.530	0.0792	0.0037	0.0127	0.0111	0.146	0.289	0.329	-0.231	0.0	0.0009	0.0000
L 1x1x1/8	0.234	1.00	0.1250	1.00	0.1250	45.0	0.104	0.0345	0.0488	0.0488	0.384	0.707	0.707	0.105	0.0090	0.0238	0.0214	0.196	0.377	0.418	-0.323	0.0	0.0012	0.0001
L 1x1x3/16	0.340	1.00	0.1875	1.00	0.1875	45.0	0.163	0.0470	0.0665	0.0665	0.372	0.707	0.707	0.159	0.0129	0.0330	0.0286	0.195	0.390	0.450	-0.301	0.0	0.0040	0.0003
L 1x1x1/4	0.438	1.00	0.2500	1.00	0.2500	45.0	0.231	0.0570	0.0806	0.0806	0.361	0.707	0.707	0.217	0.0168	0.0415	0.0350	0.196	0.404	0.480	-0.274	0.0	0.0091	0.0006
L 1-1/4x1-1/4x1/8	0.297	1.25	0.1250	1.25	0.1250	45.0	0.129	0.0700	0.0792	0.0792	0.485	0.884	0.884	0.131	0.0179	0.0385	0.0354	0.246	0.465	0.507	-0.413	0.0	0.0015	0.0002
L 1-1/4x1-1/4x3/16	0.434	1.25	0.1875	1.25	0.1875	45.0	0.198	0.0972	0.110	0.110	0.474	0.884	0.884	0.197	0.0257	0.0539	0.0478	0.244	0.478	0.539	-0.393	0.0	0.0051	0.0006
L 1-1/4x1-1/4x1/4	0.563	1.25	0.2500	1.25	0.2500	45.0	0.274	0.120	0.136	0.136	0.462	0.884	0.884	0.266	0.0333	0.0678	0.0585	0.243	0.491	0.570	-0.370	0.0	0.0117	0.0012
L 1-1/2x1-1/2x1/8	0.359	1.50	0.1250	1.50	0.1250	45.0	0.154	0.124	0.117	0.117	0.587	1.06	1.06	0.156	0.0315	0.0570	0.0529	0.296	0.553	0.596	-0.503	0.0	0.0019	0.0003
L 1-1/2x1-1/2x3/16	0.527	1.50	0.1875	1.50	0.1875	45.0	0.234	0.175	0.165	0.165	0.575	1.06	1.06	0.236	0.0454	0.0802	0.0723	0.293	0.566	0.628	-0.484	0.0	0.0062	0.0010
L 1-1/2x1-1/2x1/4	0.688	1.50	0.2500	1.50	0.2500	45.0	0.320	0.218	0.206	0.206	0.564	1.06	1.06	0.317	0.0586	0.101	0.0890	0.292	0.579	0.659	-0.463	0.0	0.0143	0.0023
L 2x2x1/8	0.484	2.00	0.1250	2.00	0.1250	45.0	0.205	0.303	0.215	0.215	0.791	1.41	1.41	0.208	0.0766	0.105	0.0991	0.398	0.730	0.773	-0.681	0.0	0.0025	0.0008
L 2x2x3/16	0.715	2.00	0.1875	2.00	0.1875	45.0	0.308	0.434	0.307	0.307	0.779	1.41	1.41	0.313	0.111	0.149	0.138	0.394	0.742	0.805	-0.664	0.0	0.0084	0.0025
L 2x2x1/4	0.938	2.00	0.2500	2.00	0.2500	45.0	0.416	0.552	0.390	0.390	0.767	1.41	1.41	0.419	0.143	0.190	0.171	0.391	0.754	0.837	-0.646	0.0	0.0195	0.0057
L 2x2x3/8	1.36	2.00	0.3750	2.00	0.3750	45.0	0.650	0.752	0.532	0.532	0.744	1.41	1.41	0.637	0.206	0.264	0.229	0.389	0.780	0.899	-0.601	0.0	0.0637	0.0174
L 2-1/2x2-1/2x3/16	0.902	2.50	0.1875	2.50	0.1875	45.0	0.384	0.872	0.493	0.493	0.983	1.77	1.77	0.391	0.221	0.241	0.225	0.495	0.918	0.982	-0.843	0.0	0.0106	0.0051
L 2-1/2x2-1/2x1/4	1.19	2.50	0.2500	2.50	0.2500	45.0	0.515	1.12	0.633	0.633	0.971	1.77	1.77	0.522	0.287	0.308	0.283	0.491	0.930	1.01	-0.826	0.0	0.0247	0.0116
L 2-1/2x2-1/2x3/8	1.73	2.50	0.3750	2.50	0.3750	45.0	0.790	1.56	0.880	0.880	0.947	1.77	1.77	0.789	0.412	0.431	0.382	0.487	0.956	1.08	-0.786	0.0	0.0813	0.0362
L 3x3x3/16	1.09	3.00	0.1875	3.00	0.1875	45.0	0.461	1.54	0.724	0.724	1.19	2.12	2.12	0.469	0.388	0.354	0.334	0.596	1.09	1.16	-1.02	0.0	0.0128	0.0090
L 3x3x1/4	1.44	3.00	0.2500	3.00	0.2500	45.0	0.616	1.98	0.935	0.935	1.17	2.12	2.12	0.626	0.504	0.456	0.423	0.592	1.11	1.19	-1.01	0.0	0.0299	0.0206
L 3x3x5/16	1.78	3.00	0.3125	3.00	0.3125	45.0	0.773	2.40	1.13	1.13	1.16	2.12	2.12	0.784	0.617	0.551	0.504	0.589	1.12	1.22	-0.988	0.0	0.0579	0.0390

Copyright ©2007 by Stainless Structures, LLC

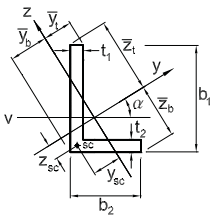

# L Shapes EQUAL LEGS (Principal Axes y, z)

## Dimensions and Properties

Shape	A	Leg1		Leg2		$\alpha$	Axis y-y						Axis z-z						Shear Center		Torsion Properties			
		$b_1$	$t_1$	$b_2$	$t_2$		$A_y$	$I_y$	$S_y^{top}$	$S_y^{bot}$	$r_y$	$\bar{z}_t$	$\bar{z}_b$	$A_z$	$I_z$	$S_z^{top}$	$S_z^{bot}$	$r_z$	$\bar{y}_t$	$\bar{y}_b$	$y_{sc}$	$z_{sc}$	J	$C_w$
		in. <sup>2</sup>	in.	in.	in.		in.	deg.	in. <sup>2</sup>	in. <sup>4</sup>	in. <sup>3</sup>	in. <sup>3</sup>	in.	in.	in.	in. <sup>2</sup>	in. <sup>4</sup>	in. <sup>3</sup>	in. <sup>3</sup>	in.	in.	in.	in.	in.
L 3x3x3/8	2.11	3.00	0.3750	3.00	0.3750	45.0	0.935	2.79	1.32	1.32	1.15	2.12	2.12	0.943	0.726	0.642	0.579	0.587	1.13	1.26	-0.969	0.0	0.0989	0.0652
L 3x3x1/2	2.75	3.00	0.5000	3.00	0.5000	45.0	1.28	3.49	1.65	1.65	1.13	2.12	2.12	1.27	0.938	0.811	0.712	0.584	1.16	1.32	-0.926	0.0	0.229	0.144
L 3-1/2x3-1/2x1/4	1.69	3.50	0.2500	3.50	0.2500	45.0	0.717	3.21	1.30	1.30	1.38	2.47	2.47	0.729	0.812	0.633	0.593	0.694	1.28	1.37	-1.18	0.0	0.0352	0.0334
L 3-1/2x3-1/2x3/8	2.48	3.50	0.3750	3.50	0.3750	45.0	1.08	4.56	1.84	1.84	1.35	2.47	2.47	1.10	1.17	0.897	0.818	0.687	1.31	1.43	-1.15	0.0	0.116	0.106
L 4x4x1/4	1.94	4.00	0.2500	4.00	0.2500	45.0	0.820	4.85	1.72	1.72	1.58	2.83	2.83	0.833	1.22	0.839	0.793	0.795	1.46	1.55	-1.36	0.0	0.0404	0.0505
L 4x4x3/8	2.86	4.00	0.3750	4.00	0.3750	45.0	1.23	6.94	2.45	2.45	1.56	2.83	2.83	1.25	1.77	1.20	1.10	0.788	1.48	1.61	-1.33	0.0	0.134	0.162
L 4x4x1/2	3.75	4.00	0.5000	4.00	0.5000	45.0	1.66	8.83	3.12	3.12	1.53	2.83	2.83	1.68	2.29	1.52	1.37	0.782	1.51	1.67	-1.29	0.0	0.313	0.366
L 5x5x1/4	2.44	5.00	0.2500	5.00	0.2500	45.0	1.03	9.66	2.73	2.73	1.99	3.54	3.54	1.04	2.43	1.34	1.28	0.998	1.81	1.90	-1.72	0.0	0.0508	0.101
L 5x5x3/8	3.61	5.00	0.3750	5.00	0.3750	45.0	1.54	14.0	3.95	3.95	1.97	3.54	3.54	1.56	3.54	1.93	1.80	0.990	1.84	1.96	-1.69	0.0	0.169	0.327
L 5x5x1/2	4.75	5.00	0.5000	5.00	0.5000	45.0	2.06	17.9	5.07	5.07	1.94	3.54	3.54	2.09	4.59	2.47	2.26	0.983	1.86	2.03	-1.65	0.0	0.396	0.744
L 6x6x1/4	2.94	6.00	0.2500	6.00	0.2500	45.0	1.23	16.9	3.98	3.98	2.40	4.24	4.24	1.25	4.24	1.96	1.88	1.20	2.17	2.25	-2.07	0.0	0.0612	0.176
L 6x6x3/8	4.36	6.00	0.3750	6.00	0.3750	45.0	1.84	24.6	5.79	5.79	2.37	4.24	4.24	1.87	6.20	2.83	2.67	1.19	2.19	2.32	-2.04	0.0	0.204	0.575
L 6x6x1/2	5.75	6.00	0.5000	6.00	0.5000	45.0	2.46	31.7	7.48	7.48	2.35	4.24	4.24	2.50	8.07	3.65	3.39	1.18	2.21	2.38	-2.01	0.0	0.479	1.32

# Part 1

## L Shapes Equal Legs Dimensions and Properties(Axes u,v)

### DIMENSIONS AND PROPERTIES OF EQUAL LEG SINGLE ANGLE SHAPES

Dimensions and properties of equal leg single angle shapes according to principal axes u,v are given in this section. The following notations are used in these tables.

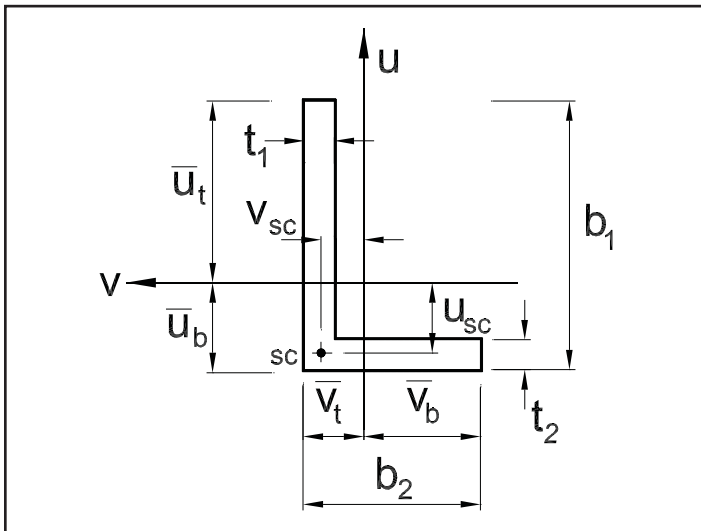

- A** Gross cross sectional area of the section
- b<sub>1</sub>** Full nominal length of leg 1
- t<sub>1</sub>** Leg 1 thickness
- b<sub>2</sub>** Full nominal length of leg 2
- t<sub>2</sub>** Leg 2 thickness
- A<sub>v</sub>** Shear area with respect to the axis v
- I<sub>v</sub>** Moment of inertia about the axis v
- S<sub>v</sub><sup>top</sup>** Positive u-direction elastic section modulus corresponding to the axis v
- S<sub>v</sub><sup>bot</sup>** Negative u-direction elastic section modulus corresponding to the axis v
- r<sub>v</sub>** Radius of gyration corresponding to the axis v
- ū<sub>t</sub>** Positive u direction distance from the centroid to the extreme fiber
- ū<sub>b</sub>** Negative u direction distance from the centroid to the extreme fiber
- A<sub>u</sub>** Shear area with respect to the axis u
- I<sub>u</sub>** Moment of inertia about the axis u
- S<sub>u</sub><sup>top</sup>** Positive v-direction elastic section modulus corresponding to the axis u
- S<sub>u</sub><sup>bot</sup>** Negative v-direction elastic section modulus corresponding to the axis u
- r<sub>u</sub>** Radius of gyration corresponding to the axis u
- v̄<sub>t</sub>** Positive v direction distance from the centroid to the extreme fiber
- v̄<sub>b</sub>** Negative v direction distance from the centroid to the extreme fiber
- I<sub>uv</sub>** Product moment of inertia about the axes u, v
- u<sub>sc</sub>** u-coordinate of the shear center
- v<sub>sc</sub>** v-coordinate of the shear center
- J** Torsion constant
- C<sub>w</sub>** Warping constant
- SC** Shear center

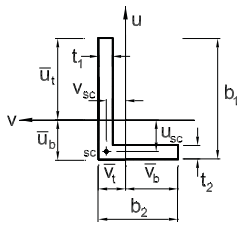

# L Shapes EQUAL LEGS (Axes u, v)

## Dimensions and Properties

Shape	A	Leg1		Leg2		Axis v-v						Axis u-u						Axis u-v	Shear Center		Torsion Properties				
		b <sub>1</sub>	t <sub>1</sub>	b <sub>2</sub>	t <sub>2</sub>	A <sub>v</sub>	I <sub>v</sub>	S <sub>v</sub> <sup>top</sup>	S <sub>v</sub> <sup>bot</sup>	r <sub>v</sub>	u <sub>t</sub>	u <sub>b</sub>	A <sub>u</sub>	I <sub>u</sub>	S <sub>u</sub> <sup>top</sup>	S <sub>u</sub> <sup>bot</sup>	r <sub>u</sub>		v <sub>t</sub>	v <sub>b</sub>	I <sub>uv</sub>	u <sub>sc</sub>	v <sub>sc</sub>	J	C <sub>w</sub>
		in.	in.	in.	in.	in. <sup>2</sup>	in. <sup>4</sup>	in. <sup>3</sup>	in. <sup>3</sup>	in.	in.	in.	in. <sup>2</sup>	in. <sup>4</sup>	in. <sup>3</sup>	in. <sup>3</sup>	in.		in.	in.	in.	in. <sup>4</sup>	in.	in.	in. <sup>4</sup>
L 1/2-1/2x1/8	0.109	0.50	0.1250	0.50	0.1250	0.0559	0.0023	0.0070	0.0136	0.145	0.330	0.170	0.0559	0.0023	0.0136	0.0070	0.145	0.170	0.330	0.0013	-0.0967	0.0967	0.0006	0.0000	
L 3/4-3/4x1/8	0.172	0.75	0.1250	0.75	0.1250	0.0796	0.0087	0.0167	0.0372	0.224	0.517	0.233	0.0796	0.0087	0.0372	0.0167	0.224	0.233	0.517	0.0050	-0.164	0.164	0.0009	0.0000	
L 1x1x1/8	0.234	1.00	0.1250	1.00	0.1250	0.104	0.0217	0.0309	0.0734	0.304	0.704	0.296	0.104	0.0217	0.0734	0.0309	0.304	0.296	0.704	0.0128	-0.228	0.228	0.0012	0.0001	
L 1x1x3/16	0.340	1.00	0.1875	1.00	0.1875	0.161	0.0299	0.0439	0.0942	0.297	0.682	0.318	0.161	0.0299	0.0942	0.0439	0.297	0.318	0.682	0.0171	-0.213	0.213	0.0040	0.0003	
L 1x1x1/4	0.438	1.00	0.2500	1.00	0.2500	0.224	0.0369	0.0558	0.109	0.290	0.661	0.339	0.224	0.0369	0.109	0.0558	0.290	0.339	0.661	0.0201	-0.193	0.193	0.0091	0.0006	
L 1-1/4x1-1/4x1/8	0.297	1.25	0.1250	1.25	0.1250	0.130	0.0439	0.0493	0.123	0.385	0.891	0.359	0.130	0.0439	0.123	0.0493	0.385	0.359	0.891	0.0260	-0.292	0.292	0.0015	0.0002	
L 1-1/4x1-1/4x3/16	0.434	1.25	0.1875	1.25	0.1875	0.197	0.0615	0.0708	0.161	0.377	0.869	0.381	0.197	0.0615	0.161	0.0708	0.377	0.381	0.869	0.0358	-0.278	0.278	0.0051	0.0006	
L 1-1/4x1-1/4x1/4	0.563	1.25	0.2500	1.25	0.2500	0.270	0.0767	0.0905	0.190	0.369	0.847	0.403	0.270	0.0767	0.190	0.0905	0.369	0.403	0.847	0.0434	-0.261	0.261	0.0117	0.0012	
L 1-1/2x1-1/2x1/8	0.359	1.50	0.1250	1.50	0.1250	0.155	0.0778	0.0721	0.185	0.465	1.08	0.421	0.155	0.0778	0.185	0.0721	0.465	0.421	1.08	0.0462	-0.355	0.355	0.0019	0.0003	
L 1-1/2x1-1/2x3/16	0.527	1.50	0.1875	1.50	0.1875	0.235	0.110	0.104	0.248	0.457	1.06	0.444	0.235	0.110	0.248	0.104	0.457	0.444	1.06	0.0646	-0.342	0.342	0.0062	0.0010	
L 1-1/2x1-1/2x1/4	0.688	1.50	0.2500	1.50	0.2500	0.318	0.139	0.134	0.297	0.449	1.03	0.466	0.318	0.139	0.297	0.134	0.449	0.466	1.03	0.0799	-0.327	0.327	0.0143	0.0023	
L 2x2x1/8	0.484	2.00	0.1250	2.00	0.1250	0.207	0.190	0.131	0.348	0.626	1.45	0.546	0.207	0.190	0.348	0.131	0.626	0.546	1.45	0.113	-0.481	0.481	0.0025	0.0008	
L 2x2x3/16	0.715	2.00	0.1875	2.00	0.1875	0.311	0.272	0.190	0.479	0.617	1.43	0.569	0.311	0.272	0.479	0.190	0.617	0.569	1.43	0.162	-0.470	0.470	0.0084	0.0025	
L 2x2x1/4	0.938	2.00	0.2500	2.00	0.2500	0.417	0.348	0.247	0.587	0.609	1.41	0.592	0.417	0.348	0.587	0.247	0.609	0.592	1.41	0.204	-0.457	0.457	0.0195	0.0057	
L 2x2x3/8	1.36	2.00	0.3750	2.00	0.3750	0.643	0.479	0.351	0.754	0.594	1.36	0.636	0.643	0.479	0.754	0.351	0.594	0.636	1.36	0.273	-0.425	0.425	0.0637	0.0174	
L 2-1/2x2-1/2x3/16	0.902	2.50	0.1875	2.50	0.1875	0.388	0.547	0.303	0.787	0.778	1.81	0.694	0.388	0.547	0.787	0.303	0.778	0.694	1.81	0.326	-0.596	0.596	0.0106	0.0051	
L 2-1/2x2-1/2x1/4	1.19	2.50	0.2500	2.50	0.2500	0.518	0.703	0.394	0.981	0.769	1.78	0.717	0.518	0.703	0.981	0.394	0.769	0.717	1.78	0.416	-0.584	0.584	0.0247	0.0116	
L 2-1/2x2-1/2x3/8	1.73	2.50	0.3750	2.50	0.3750	0.790	0.984	0.566	1.29	0.753	1.74	0.762	0.790	0.984	1.29	0.566	0.753	0.762	1.74	0.572	-0.556	0.556	0.0813	0.0362	
L 3x3x3/16	1.09	3.00	0.1875	3.00	0.1875	0.465	0.962	0.441	1.17	0.939	2.18	0.820	0.465	0.962	1.17	0.441	0.939	0.820	2.18	0.574	-0.722	0.722	0.0128	0.0090	
L 3x3x1/4	1.44	3.00	0.2500	3.00	0.2500	0.621	1.24	0.577	1.48	0.930	2.16	0.842	0.621	1.24	1.48	0.577	0.930	0.842	2.16	0.740	-0.711	0.711	0.0299	0.0206	
L 3x3x5/16	1.78	3.00	0.3125	3.00	0.3125	0.778	1.51	0.707	1.75	0.922	2.13	0.865	0.778	1.51	1.75	0.707	0.922	0.865	2.13	0.893	-0.698	0.698	0.0579	0.0390	

Copyright ©2007 by Stainless Structural, LLC

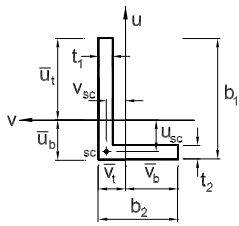

# L Shapes EQUAL LEGS (Axes u, v)

## Dimensions and Properties

Shape	A	Leg1		Leg2		Axis v-v						Axis u-u						Axis u-v	Shear Center		Torsion Properties			
		b <sub>1</sub>	t <sub>1</sub>	b <sub>2</sub>	t <sub>2</sub>	A <sub>v</sub>	I <sub>v</sub>	S <sub>v</sub> <sup>top</sup>	S <sub>v</sub> <sup>bot</sup>	r <sub>v</sub>	u <sub>t</sub>	u <sub>b</sub>	A <sub>u</sub>	I <sub>u</sub>	S <sub>u</sub> <sup>top</sup>	S <sub>u</sub> <sup>bot</sup>	r <sub>u</sub>	v <sub>t</sub>	v <sub>b</sub>	I <sub>uv</sub>	u <sub>sc</sub>	v <sub>sc</sub>	J	C <sub>w</sub>
		in. <sup>2</sup>	in.	in.	in.	in.	in. <sup>2</sup>	in. <sup>4</sup>	in. <sup>3</sup>	in. <sup>3</sup>	in.	in.	in.	in. <sup>2</sup>	in. <sup>4</sup>	in. <sup>3</sup>	in. <sup>3</sup>	in.	in.	in.	in. <sup>4</sup>	in.	in.	in. <sup>4</sup>
L 3x3x3/8	2.11	3.00	0.3750	3.00	0.3750	0.939	1.76	0.833	1.98	0.913	2.11	0.888	0.939	1.76	1.98	0.833	0.913	0.888	2.11	1.03	-0.685	0.685	0.0989	0.0652
L 3x3x1/2	2.75	3.00	0.5000	3.00	0.5000	1.27	2.22	1.07	2.38	0.898	2.07	0.932	1.27	2.22	2.38	1.07	0.898	0.932	2.07	1.28	-0.655	0.655	0.229	0.144
L 3-1/2x3-1/2x1/4	1.69	3.50	0.2500	3.50	0.2500	0.723	2.01	0.794	2.08	1.09	2.53	0.968	0.723	2.01	2.08	0.794	1.09	0.968	2.53	1.20	-0.837	0.837	0.0352	0.0334
L 3-1/2x3-1/2x3/8	2.48	3.50	0.3750	3.50	0.3750	1.09	2.87	1.15	2.83	1.07	2.49	1.01	1.09	2.87	2.83	1.15	1.07	1.01	2.49	1.69	-0.813	0.813	0.116	0.106
L 4x4x1/4	1.94	4.00	0.2500	4.00	0.2500	0.826	3.04	1.05	2.78	1.25	2.91	1.09	0.826	3.04	2.78	1.05	1.25	1.09	2.91	1.81	-0.963	0.963	0.0404	0.0505
L 4x4x3/8	2.86	4.00	0.3750	4.00	0.3750	1.24	4.36	1.52	3.83	1.23	2.86	1.14	1.24	4.36	3.83	1.52	1.23	1.14	2.86	2.59	-0.940	0.940	0.134	0.162
L 4x4x1/2	3.75	4.00	0.5000	4.00	0.5000	1.67	5.56	1.97	4.70	1.22	2.82	1.18	1.67	5.56	4.70	1.97	1.22	1.18	2.82	3.27	-0.913	0.913	0.313	0.366
L 5x5x1/4	2.44	5.00	0.2500	5.00	0.2500	1.03	6.05	1.65	4.50	1.57	3.66	1.34	1.03	6.05	4.50	1.65	1.57	1.34	3.66	3.62	-1.21	1.21	0.0508	0.101
L 5x5x3/8	3.61	5.00	0.3750	5.00	0.3750	1.55	8.74	2.42	6.30	1.56	3.61	1.39	1.55	8.74	6.30	2.42	1.56	1.39	3.61	5.21	-1.19	1.19	0.169	0.327
L 5x5x1/2	4.75	5.00	0.5000	5.00	0.5000	2.07	11.3	3.16	7.84	1.54	3.57	1.43	2.07	11.3	7.84	3.16	1.54	1.43	3.57	6.66	-1.17	1.17	0.396	0.744
L 6x6x1/4	2.94	6.00	0.2500	6.00	0.2500	1.24	10.6	2.40	6.64	1.90	4.41	1.59	1.24	10.6	6.64	2.40	1.90	1.59	4.41	6.33	-1.46	1.46	0.0612	0.176
L 6x6x3/8	4.36	6.00	0.3750	6.00	0.3750	1.86	15.4	3.53	9.39	1.88	4.36	1.64	1.86	15.4	9.39	3.53	1.88	1.64	4.36	9.19	-1.44	1.44	0.204	0.575
L 6x6x1/2	5.75	6.00	0.5000	6.00	0.5000	2.48	19.9	4.61	11.8	1.86	4.32	1.68	2.48	19.9	11.8	4.61	1.86	1.68	4.32	11.8	-1.42	1.42	0.479	1.32

# Part 1

## L Shapes Unequal Legs Dimensions and Properties (Principal Axes y,z)

### DIMENSIONS AND PROPERTIES OF LASER-FUSED AND HOT-ROLLED UNEQUAL LEG SINGLE ANGLE SHAPES

Dimensions and properties of laser-fused and hot-rolled unequal single angle shapes according to principal axes y,z are given in this section. The following notations are used in these tables.

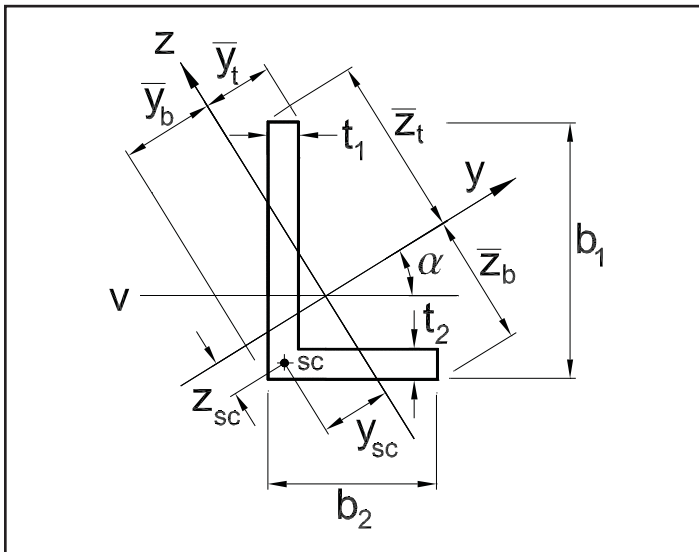

- A** Gross cross sectional area of the section
- $b_1$**  Full nominal length of leg 1
- $t_1$**  Leg 1 thickness
- $b_2$**  Full nominal length of leg 2
- $t_2$**  Leg 2 thickness
- $\alpha$**  Principal angle
- $A_y$**  Shear area with respect to the principal axis y
- $I_y$**  Moment of inertia about the principal axis y
- $S_y^{\text{top}}$**  Positive z-direction elastic section modulus corresponding to the principal axis y
- $S_y^{\text{bot}}$**  Negative z-direction elastic section modulus corresponding to the principal axis y
- $r_y$**  Radius of gyration corresponding to the principal axis y
- $\bar{z}_t$**  Positive z direction distance from the centroid to the extreme fiber
- $\bar{z}_b$**  Negative z direction distance from the centroid to the extreme fiber
- $A_z$**  Shear area with respect to the principal axis z
- $I_z$**  Moment of inertia about the principal axis z
- $S_z^{\text{top}}$**  Positive y-direction elastic section modulus corresponding to the principal axis z
- $S_z^{\text{bot}}$**  Negative y-direction elastic section modulus corresponding to the principal axis z
- $r_z$**  Radius of gyration corresponding to the principal axis z
- $\bar{y}_t$**  Positive y direction distance from the centroid to the extreme fiber
- $\bar{y}_b$**  Negative y direction distance from the centroid to the extreme fiber
- $y_{sc}$**  y-coordinate of the shear center
- $z_{sc}$**  z-coordinate of the shear center
- J** Torsion constant
- $C_w$**  Warping constant
- SC** Shear center

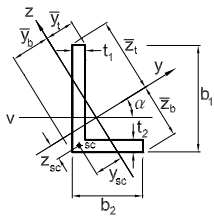

# L Shapes UNEQUAL LEGS (Laser Fused) (Principal Axes y, z)

## Dimensions and Properties

Shape	A	Leg1		Leg2		$\alpha$	Axis y-y						Axis z-z						Shear Center		Torsion Properties			
		$b_1$	$t_1$	$b_2$	$t_2$		$A_y$	$I_y$	$S_y^{top}$	$S_y^{bot}$	$r_y$	$\bar{z}_t$	$\bar{z}_b$	$A_z$	$I_z$	$S_z^{top}$	$S_z^{bot}$	$r_z$	$\bar{y}_t$	$\bar{y}_b$	$y_{sc}$	$z_{sc}$	J	$C_w$
		in. <sup>2</sup>	in.	in.	deg.		in. <sup>2</sup>	in. <sup>4</sup>	in. <sup>3</sup>	in. <sup>3</sup>	in.	in.	in.	in. <sup>2</sup>	in. <sup>4</sup>	in. <sup>3</sup>	in. <sup>3</sup>	in.	in.	in.	in.	in.	in. <sup>4</sup>	in. <sup>6</sup>
L 6x3x1/4	2.19	6.00	0.2500	3.00	0.2500	15.3	0.574	8.95	2.28	3.37	2.02	3.92	2.66	1.25	0.947	0.517	0.840	0.658	1.83	1.13	-0.970	-1.75	0.0464	0.0983
L 6x4x1/4	2.44	6.00	0.2500	4.00	0.2500	24.3	0.845	10.8	2.62	3.59	2.10	4.11	3.00	1.21	1.92	0.890	1.20	0.887	2.16	1.59	-1.42	-1.29	0.0518	0.113
L 8x4x1/4	2.94	8.00	0.2500	4.00	0.2500	15.4	0.765	21.6	4.12	6.14	2.71	5.25	3.52	1.67	2.30	0.937	1.56	0.885	2.45	1.47	-1.31	-2.35	0.0625	0.237
L 8x4x3/8	4.36	8.00	0.3750	4.00	0.3750	15.2	1.15	31.5	6.04	8.89	2.69	5.22	3.55	2.50	3.33	1.36	2.19	0.874	2.44	1.52	-1.28	-2.32	0.208	0.780

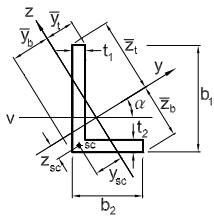

# L Shapes UNEQUAL LEGS (Hot Rolled) (Principal Axes y, z)

## Dimensions and Properties

Shape	A in. <sup>2</sup>	Leg1		Leg2		$\alpha$ deg.	Axis y-y						Axis z-z						Shear Center		Torsion Properties			
		$b_1$ in.	$t_1$ in.	$b_2$ in.	$t_2$ in.		$A_y$ in. <sup>2</sup>	$I_y$ in. <sup>4</sup>	$S_y^{top}$ in. <sup>3</sup>	$S_y^{bot}$ in. <sup>3</sup>	$r_y$ in.	$\bar{z}_t$ in.	$\bar{z}_b$ in.	$A_z$ in. <sup>2</sup>	$I_z$ in. <sup>4</sup>	$S_z^{top}$ in. <sup>3</sup>	$S_z^{bot}$ in. <sup>3</sup>	$r_z$ in.	$\bar{y}_t$ in.	$\bar{y}_b$ in.	$y_{sc}$ in.	$z_{sc}$ in.	J in. <sup>4</sup>	$C_w$ in. <sup>6</sup>
		L 2x1x1/4	0.688	2.00	0.2500		1.00	0.2500	13.9	0.218	0.287	0.227	0.313	0.646	1.27	0.916	0.416	0.0307	0.0517	0.0704	0.211	0.594	0.436	-0.274
L 3x1-1/2x1/4	1.06	3.00	0.2500	1.50	0.2500	14.6	0.298	1.04	0.539	0.770	0.990	1.93	1.35	0.624	0.109	0.121	0.179	0.321	0.904	0.611	-0.451	-0.830	0.0221	0.0114
L 3x2x3/16	0.900	3.00	0.1875	2.00	0.1875	24.0	0.316	0.972	0.475	0.644	1.04	2.05	1.51	0.451	0.173	0.161	0.210	0.439	1.08	0.825	-0.696	-0.635	0.0105	0.0057
L 3x2x1/4	1.19	3.00	0.2500	2.00	0.2500	23.8	0.427	1.25	0.616	0.827	1.03	2.04	1.52	0.603	0.225	0.208	0.264	0.435	1.08	0.852	-0.678	-0.623	0.0247	0.0132
L 3x2x3/8	1.73	3.00	0.3750	2.00	0.3750	23.2	0.663	1.75	0.870	1.15	1.01	2.01	1.53	0.909	0.320	0.296	0.354	0.430	1.08	0.904	-0.638	-0.592	0.0804	0.0413
L 4x3x1/4	1.69	4.00	0.2500	3.00	0.2500	29.2	0.647	3.41	1.23	1.56	1.42	2.77	2.18	0.794	0.716	0.478	0.575	0.651	1.50	1.25	-1.07	-0.662	0.0353	0.0356
L 4x3x3/8	2.48	4.00	0.3750	3.00	0.3750	28.8	0.979	4.85	1.76	2.21	1.40	2.76	2.19	1.19	1.03	0.684	0.790	0.644	1.51	1.30	-1.03	-0.647	0.116	0.114
L 5x3x1/4	1.94	5.00	0.2500	3.00	0.2500	20.4	0.615	5.70	1.69	2.40	1.71	3.36	2.37	1.02	0.851	0.499	0.714	0.663	1.71	1.19	-1.03	-1.23	0.0406	0.0606
L 5x3x3/8	2.86	5.00	0.3750	3.00	0.3750	20.0	0.932	8.19	2.45	3.43	1.69	3.34	2.39	1.53	1.22	0.719	0.983	0.654	1.70	1.24	-0.993	-1.21	0.134	0.196
L 6x3x3/8	3.23	6.00	0.3750	3.00	0.3750	15.0	0.872	12.9	3.33	4.83	2.00	3.89	2.68	1.87	1.36	0.748	1.16	0.649	1.82	1.18	-0.937	-1.71	0.152	0.320
L 6x4x3/8	3.61	6.00	0.3750	4.00	0.3750	24.0	1.27	15.6	3.81	5.17	2.08	4.09	3.02	1.81	2.78	1.29	1.68	0.877	2.16	1.65	-1.39	-1.27	0.170	0.369
L 6x4x1/2	4.75	6.00	0.5000	4.00	0.5000	23.8	1.71	20.1	4.93	6.62	2.06	4.07	3.03	2.41	3.59	1.66	2.11	0.870	2.16	1.70	-1.36	-1.25	0.396	0.843

# Part 1

## L Shapes Unequal Legs Dimensions and Properties (Axes u,v)

### DIMENSIONS AND PROPERTIES OF LASER-FUSED AND HOT ROLLED UNEQUAL LEG SINGLE ANGLE SHAPES

Dimensions and properties of laser-fused and hot-rolled unequal single angle shapes according to axes u,v are given in this section. The following notations are used in these tables.

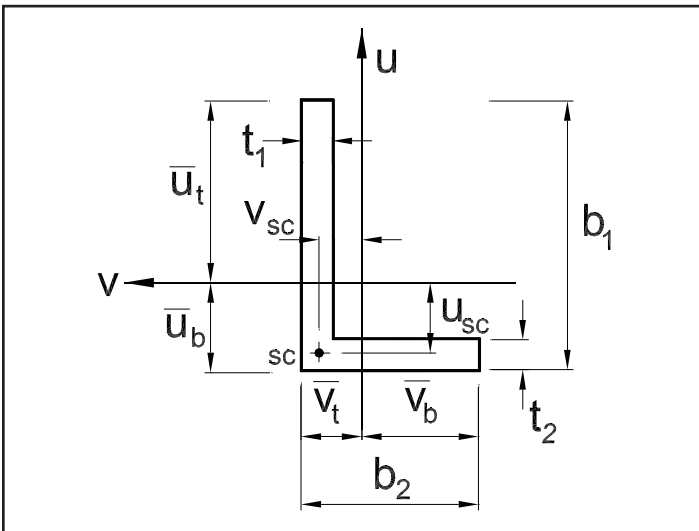

- A** Gross cross sectional area of the section
- b<sub>1</sub>** Full nominal length of leg 1
- t<sub>1</sub>** Leg 1 thickness
- b<sub>2</sub>** Full nominal length of leg 2
- t<sub>2</sub>** Leg 2 thickness
- A<sub>v</sub>** Shear area with respect to the axis v
- I<sub>v</sub>** Moment of inertia about the axis v
- S<sub>v</sub><sup>top</sup>** Positive u-direction elastic section modulus corresponding to the axis v
- S<sub>v</sub><sup>bot</sup>** Negative u-direction elastic section modulus corresponding to the axis v
- r<sub>v</sub>** Radius of gyration corresponding to the axis v
- $\bar{u}_t$**  Positive u direction distance from the centroid to the extreme fiber
- $\bar{u}_b$**  Negative u direction distance from the centroid to the extreme fiber
- A<sub>u</sub>** Shear area with respect to the axis u
- I<sub>u</sub>** Moment of inertia about the axis u
- S<sub>u</sub><sup>top</sup>** Positive v-direction elastic section modulus corresponding to the axis u
- S<sub>u</sub><sup>bot</sup>** Negative v-direction elastic section modulus corresponding to the axis u
- r<sub>u</sub>** Radius of gyration corresponding to the axis u
- $\bar{v}_t$**  Positive v direction distance from the centroid to the extreme fiber
- $\bar{v}_b$**  Negative v direction distance from the centroid to the extreme fiber
- I<sub>uv</sub>** Product moment of inertia about the axes u, v
- u<sub>sc</sub>** u-coordinate of the shear center
- v<sub>sc</sub>** v-coordinate of the shear center
- J** Torsion constant
- C<sub>w</sub>** Warping constant
- SC** Shear center

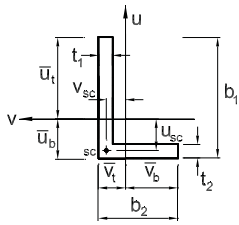

# L Shapes UNEQUAL LEGS (Laser Fused) (Axes u,v)

## Dimensions and Properties

Shape	A in. <sup>2</sup>	Leg1		Leg2		Axis v-v						Axis u-u						Axis u-v		Shear Center		Torsion Properties		
		b <sub>1</sub> in.	t <sub>1</sub> in.	b <sub>2</sub> in.	t <sub>2</sub> in.	A <sub>v</sub> in. <sup>2</sup>	I <sub>v</sub> in. <sup>4</sup>	S <sub>v</sub> <sup>top</sup> in. <sup>3</sup>	S <sub>v</sub> <sup>bot</sup> in. <sup>3</sup>	r <sub>v</sub> in.	u <sub>t</sub> in.	u <sub>b</sub> in.	A <sub>u</sub> in. <sup>2</sup>	I <sub>u</sub> in. <sup>4</sup>	S <sub>u</sub> <sup>top</sup> in. <sup>3</sup>	S <sub>u</sub> <sup>bot</sup> in. <sup>3</sup>	r <sub>u</sub> in.	v <sub>t</sub> in.	v <sub>b</sub> in.	I <sub>uv</sub> in. <sup>4</sup>	u <sub>sc</sub> in.	v <sub>sc</sub> in.	J in. <sup>4</sup>	C <sub>w</sub> in. <sup>6</sup>
		L 6x3x1/4	2.19	6.00	0.2500	3.00	0.2500	0.537	8.40	2.15	4.01	1.96	3.90	2.10	1.29	1.50	2.52	0.625	1.96	0.596	2.40	2.03	-1.95	0.475
L 6x4x1/4	2.44	6.00	0.2500	4.00	0.2500	0.772	9.27	2.26	4.90	1.95	4.11	1.89	1.28	3.41	3.82	1.10	1.95	0.894	3.11	3.32	-1.76	0.770	0.0518	0.113
L 8x4x1/4	2.94	8.00	0.2500	4.00	0.2500	0.713	20.3	3.87	7.33	2.63	5.24	2.76	1.72	3.66	4.80	1.13	2.63	0.763	3.24	4.95	-2.62	0.641	0.0625	0.237
L 8x4x3/8	4.36	8.00	0.3750	4.00	0.3750	1.08	29.6	5.71	10.5	2.61	5.19	2.81	2.58	5.27	6.49	1.65	2.61	0.811	3.19	7.13	-2.58	0.629	0.208	0.780

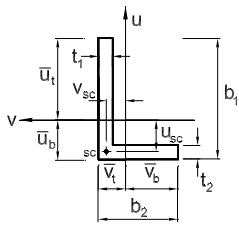

# L Shapes UNEQUAL LEGS (Hot Rolled) (Axes u,v)

## Dimensions and Properties

Shape	A	Leg1		Leg2		Axis v-v						Axis u-u						Axis u-v	Shear Center		Torsion Properties				
		b <sub>1</sub>	t <sub>1</sub>	b <sub>2</sub>	t <sub>2</sub>	A <sub>v</sub>	I <sub>v</sub>	S <sub>v</sub> <sup>top</sup>	S <sub>v</sub> <sup>bot</sup>	r <sub>v</sub>	u <sub>t</sub>	u <sub>b</sub>	A <sub>u</sub>	I <sub>u</sub>	S <sub>u</sub> <sup>top</sup>	S <sub>u</sub> <sup>bot</sup>	r <sub>u</sub>		v <sub>t</sub>	v <sub>b</sub>	I <sub>uv</sub>	u <sub>sc</sub>	v <sub>sc</sub>	J	C <sub>w</sub>
		in.	in.	in.	in.	in. <sup>2</sup>	in. <sup>4</sup>	in. <sup>3</sup>	in. <sup>3</sup>	in.	in.	in.	in. <sup>2</sup>	in. <sup>4</sup>	in. <sup>3</sup>	in. <sup>3</sup>	in.		in.	in.	in.	in. <sup>4</sup>	in.	in.	in. <sup>4</sup>
L 2x1x1/4	0.688	2.00	0.2500	1.00	0.2500	0.207	0.272	0.220	0.357	0.629	1.24	0.761	0.427	0.0455	0.174	0.0616	0.629	0.261	0.739	0.0597	-0.554	0.145	0.0141	0.0032	
L 3x1-1/2x1/4	1.06	3.00	0.2500	1.50	0.2500	0.281	0.981	0.515	0.896	0.961	1.90	1.10	0.641	0.169	0.488	0.146	0.961	0.346	1.15	0.227	-0.917	0.227	0.0221	0.0114	
L 3x2x3/16	0.900	3.00	0.1875	2.00	0.1875	0.290	0.840	0.414	0.866	0.966	2.03	0.970	0.477	0.306	0.650	0.200	0.966	0.470	1.53	0.297	-0.863	0.377	0.0105	0.0057	
L 3x2x1/4	1.19	3.00	0.2500	2.00	0.2500	0.393	1.09	0.542	1.09	0.957	2.01	0.993	0.637	0.392	0.794	0.260	0.957	0.493	1.51	0.380	-0.844	0.369	0.0247	0.0132	
L 3x2x3/8	1.73	3.00	0.3750	2.00	0.3750	0.613	1.53	0.781	1.47	0.940	1.96	1.04	0.959	0.543	1.01	0.371	0.940	0.539	1.46	0.519	-0.795	0.353	0.0804	0.0413	
L 4x3x1/4	1.69	4.00	0.2500	3.00	0.2500	0.595	2.77	1.00	2.24	1.28	2.76	1.24	0.846	1.36	1.84	0.599	1.28	0.736	2.26	1.15	-1.10	0.610	0.0353	0.0356	
L 4x3x3/8	2.48	4.00	0.3750	3.00	0.3750	0.904	3.96	1.46	3.09	1.26	2.72	1.28	1.27	1.92	2.46	0.866	1.26	0.782	2.22	1.62	-1.06	0.592	0.116	0.114	
L 5x3x1/4	1.94	5.00	0.2500	3.00	0.2500	0.566	5.11	1.53	3.08	1.62	3.34	1.66	1.07	1.44	2.19	0.614	1.62	0.657	2.34	1.58	-1.51	0.534	0.0406	0.0606	
L 5x3x3/8	2.86	5.00	0.3750	3.00	0.3750	0.862	7.37	2.24	4.33	1.61	3.30	1.70	1.60	2.04	2.90	0.888	1.61	0.704	2.30	2.24	-1.47	0.520	0.134	0.196	
L 6x3x3/8	3.23	6.00	0.3750	3.00	0.3750	0.819	12.2	3.16	5.68	1.94	3.86	2.14	1.93	2.13	3.31	0.905	1.94	0.644	2.36	2.89	-1.90	0.464	0.152	0.320	
L 6x4x3/8	3.61	6.00	0.3750	4.00	0.3750	1.16	13.5	3.32	6.94	1.93	4.06	1.94	1.91	4.90	5.21	1.60	1.93	0.941	3.06	4.77	-1.73	0.754	0.170	0.369	
L 6x4x1/2	4.75	6.00	0.5000	4.00	0.5000	1.57	17.4	4.33	8.76	1.91	4.01	1.99	2.55	6.27	6.35	2.08	1.91	0.987	3.01	6.08	-1.69	0.739	0.396	0.843	